

OPERATING INSTRUCTIONS FOR INNOTECH MAXIM DIGITAL CONTROLLERS

(For Version 6.0 and above Firmware only)



Proprietary

No part of the Innotech Maxim system's hardware, software, firmware or documentation may be reproduced, transmitted, transcribed, stored in a retrieval system, or translated into any language or computer language, in any form or by any means, without prior written permission of Mass Electronics Pty Ltd.

While great efforts have been made to assure the accuracy and clarity of this document, Mass Electronics Pty Ltd assumes no liability resulting from any omissions in this document, or from misuse of the information obtained herein. The information in this document has been carefully checked and is believed to be entirely reliable with all of the necessary information included. Mass Electronics Pty Ltd reserves the right to make changes to any products described herein to improve reliability, function, or design, and reserves the right to revise this document and make changes from time to time in content hereof with no obligation to notify any persons of revisions or changes. Mass Electronics Pty Ltd does not assume any liability arising out of the application or any use of any product or circuit described herein; neither does it convey licence under its patent rights or the rights of others.

Trademark

The term: 'WINDOWS®' used in this manual is a trademark of Microsoft Corporation.

Document Management

Change Control

Ver No	Date of Issue	Status	Changes	Description/Comment
V1.0	14/03/06	Prelim	-	For comment
V1.1	16/03/06	Prelim	Minor changes to "notes" Sect 2.8	For comment
V1.2	18/03/06	Release	Innotech Control Systems	General Release

Document Review

Reviewer	Remit
Mike Sargent	Technical Accuracy
Renee Jasen	Presentation

Document Status

Release	General Distribution
---------	----------------------

Acknowledgment

Innotech Control Systems would like to thank Kevin Taylor of Taylor Controls for his considerable contribution to production of this document.

Table of Contents

TECHNICAL MANUAL OVERVIEW	8
(i) About this Manual	8
(ii) Organisation of this Manual	8
SECTION 1 – DESCRIPTION	10
1-1 What It Is	11
1-2 What It Does	11
1-3 How It Does It	11
1-4 Maxim Configuration Software	12
1-5 Setpoints	12
SECTION 2 – OPERATION	13
2-1 Introduction	13
2-2 Menu Structure	14
2-3 Home Page	15
2-4 Flash Page Watches	17
2-5 Access Codes	18
2-6 Navigation Page	19
2-7 Status Menu	19
2-7-1 Status Menu – Watches	20
2-7-2 Status Menu – Alarms	21
2-7-3 Status Menu – IO Values	22
2-7-4 Status Menu – System Info	23
2-8 Clock – General	24
2-8-1 Clock – Set Clock	24
2-8-2 Clock – DL Saving Start/Stop	25
2-8-3 Clock – Schedule	26
2-8-3-1 Clock – Schedule – Daily – Add	27
2-8-3-2 Clock – Schedule – Daily – Edit	28
2-8-3-3 Clock – Schedule – Daily – Delete	29
2-8-3-4 Clock – Schedule – Weekly – Add	30
2-8-3-5 Clock – Schedule – Weekly – Edit	31
2-8-3-6 Clock – Schedule – Weekly – Edit – 24hr Operation	32
2-8-3-7 Clock – Schedule – Weekly – Delete	33
2-8-3-8 Clock – Schedule – Yearly – Add	34
2-8-3-9 Clock – Schedule – Yearly – Edit	35
2-8-3-10 Clock – Schedule – Yearly Delete	36
2-9 Setup – General	37
2-9-1 Setup – VAR Setup	37
2-9-2 Setup – IO Config	38
2-9-3 Setup – PID PAR	39

Operating Instructions for Innotech Maxim Digital Controllers

2-10 Commission	40
2-10-1 Commission – Run/Stop	40
2-10-2 Commission – Calibrate	40
2-10-3 Commission – Network	41
2-10-3-1 Commission – Network – Status	41
2-10-3-2 Commission – Network – Baud	42
SECTION 3 – SUPERVISOR MODE	43
3-1 Access Codes	43
3-2 Status – Watches	44
3-3 Setup – General	45
3-3-1 Setup – VAR Setup (Locking Setpoints)	45
3-3-2 Setup – IO Config	46
3-3-3 Setup – PID PAR	47
3-4 Commission	48
3-4-1 Commission – Run/Stop	48
3-4-2 Commission – Calibrate	49
3-4-3 Commission – Network	50
3-4-3-1 Commission – Network – Status	50
3-4-3-2 Commission – Network – Baud Rate	51
SECTION 4 – GLOSSARY OF TERMS	52

List of Illustrations

Figure 1 : MinMax	10
Figure 2 : Maxim I	10
Figure 3 : Maxim III	10
Figure 4 : Typical Application – Simplified Block Diagram	11
Figure 5 : Setpoint : Simplified Block Diagram.....	12
Figure 6 : Maxim Digital Controller Menu Structure.....	14
Figure 7 : Home Page Display	15
Figure 8 : Front Layout	16
Figure 9 : Flash Page.....	17
Figure 10 : Access Codes (1)	18
Figure 11 : Access Codes (2)	18
Figure 12 : Access Codes (3)	18
Figure 13 : Navigate Menu	19
Figure 14 : Status Menu.....	19
Figure 15 : Typical Watch Page	20
Figure 16 : Typical Adjustable Watch Value	20
Figure 17 : Typical Flash Page Alarm.....	21
Figure 18 : Typical Alarm Page	21
Figure 19 : Universal Inputs Page	22
Figure 20 : Digital Outputs Page.....	22
Figure 21 : Analogue Outputs Page.....	22
Figure 22 : System Information (1).....	23
Figure 23 : System Information (2).....	23
Figure 24 : System Information (3).....	23
Figure 25 : Clock Menu	24
Figure 26 : System Time/Date	24
Figure 27 : DL Saving Status	25
Figure 28 : DL Saving Start	25
Figure 29 : DL Saving Stop.....	25
Figure 30 : Schedule Edit	26
Figure 31 : Daily Add/Edit/Del	27
Figure 32 : Daily Schedule Add (1).....	27
Figure 33 : Daily Schedule Add (2).....	27
Figure 34 : Daily Add/Edit/Del	28
Figure 35 : Daily Schedule Edit (1).....	28

Operating Instructions for Innotech Maxim Digital Controllers

Figure 36 : Daily Schedule Edit (2) 28

Figure 37 : Daily Add/Edit/Del 29

Figure 38 : Daily Schedule Delete 29

Figure 39 : Weekly Schedule 30

Figure 40 : Add Weekly Schedule (1) 30

Figure 41 : Add Weekly Schedule (2) 30

Figure 42 : Weekly Schedule 31

Figure 43 : Weekly Schedule Edit (1) 31

Figure 44 : Weekly Schedule Edit (2) 31

Figure 45 : Weekly Schedule (24hr) 32

Figure 46 : Weekly Schedule Edit (24hr Operation) 32

Figure 47 : Weekly Schedule Edit (24hr)..... 32

Figure 48 : Weekly Schedule 33

Figure 49 : Weekly Schedule Delete 33

Figure 50 : Yearly Schedule..... 34

Figure 51 : Add Yearly Schedule (1)..... 34

Figure 52 : Add Yearly Schedule (2)..... 34

Figure 53 : Yearly Schedule..... 35

Figure 54 : Yearly Schedule Edit (1)..... 35

Figure 55 : Yearly Schedule Edit (2)..... 35

Figure 56 : Yearly Schedule..... 36

Figure 57 : Yearly Schedule Delete 36

Figure 58 : Setup Menu 37

Figure 59 : Variable Setup (1) 37

Figure 60 : Variable Setup (2) 37

Figure 61 : IO Config Display (1) 38

Figure 62 : IO Config Display (2) 38

Figure 63 : IO Config Display (3) 38

Figure 64 : PID Parameter 39

Figure 65 : Commission Menu Display 40

Figure 66 : Run/Stop Menu Display..... 40

Figure 67 : Calibrate Menu Display..... 40

Figure 68 : Network Menu Display 41

Figure 69 : Network Status Display 41

Figure 70 : Network Baud Rate Display 42

Figure 71 : Home Page Display..... 43

Figure 72 : Navigate Menu 43

Operating Instructions for Innotech Maxim Digital Controllers

Figure 73 : Access Codes (1)	44
Figure 74 : Access Codes (2)	44
Figure 75 : Access Codes (3)	44
Figure 76 : Setup Menu (Supervisor Mode)	45
Figure 77 : VAR Setup	45
Figure 78 : IO Config Menu (1)	46
Figure 79 : IO Config Menu (2)	46
Figure 80 : IO Config Menu (3)	46
Figure 81 : IO Values Display	47
Figure 82 : PID PAR	47
Figure 83 : Commission Display	48
Figure 84 : Run/Stop Display (1)	48
Figure 85 : Run/Stop Display (2)	48
Figure 86 : Calibrate (1)	49
Figure 87 : Calibrate (2)	49
Figure 88 : Calibrate (3)	49
Figure 89 : Calibrate (4)	50
Figure 90 : Network Status	50
Figure 91 : Network Rate (1)	51
Figure 92 : Network Rate (2)	51
Figure 93 : Network Rate (3)	51

Note: The LCD screen green background has been removed from the illustrations. This makes the screen text more visible on printed copies of this manual. When viewing actual Maxim LCD screen displays the green background is still present.

Technical Manual Overview

This instruction manual for Maxim Series Digital Controllers is part of a series of technical manuals designed to provide the customer with complete and comprehensive documentation supporting the Innotech Maxim Series Digital Controller system. It contains detailed procedures for manual (front panel) operation of the Maxim Series Digital Controller. Instructions for operation of the Maxim support software and for operation of the Maxim Series Digital Controller in a network environment are beyond the scope of this manual but are contained in other Maxim manuals. The following documents support the Innotech Maxim Series Digital Controller:-

- System Description Manual for Innotech Maxim Series System
- Installation Instructions for Innotech Maxim Series System
- Operating Instructions for Innotech Maxim Series Digital Controller (this manual)
- User Manual for Innotech Maxim Series Digital Controller (software manual)
- Operating Instructions for Innotech Maxim Series Digital Controller's Global Communications
- Data sheets for Innotech Maxim Series System Components

(i) About this Manual

This instruction manual is intended to provide the user with complete and easy-to-follow instructions for manual interrogation of the Maxim Series Digital Controller from the front panel. In preparing these instructions, Innotech assumed that the typical operator is not necessarily familiar with the operation of processor (computer) systems. For this reason, operating instructions and procedures are presented at a technically basic level and as clearly as possible.

Because each Maxim Series Digital Controller is designed to be configured to its own application requirements and since each customer's application is different, no two units have identical step-by-step operating procedures. However, the Maxim Series Digital Controller unit is user-friendly and operation is simple once the necessary operational information is explained. For this reason, operating procedures in this manual are based on typical operating scenarios.

(ii) Organisation of this Manual

This instruction manual has four sections:-

- Section 1 – Description
- Section 2 – Operation
- Section 3 – Supervisor Mode
- Section 4 – Glossary of Terms

Section 1 provides a brief description of the Innotech Maxim Series Digital Controller along with background information useful to the operator in performing operational tasks. The system description has been purposely simplified to ensure that only information which is essential to effective operation of the unit is presented. If a more technically detailed description of the system is required, refer to the System Description Manual.

Section 2 of this instruction manual provides a description of the basic operating philosophy, a detailed description of how the front panel controls and indicators operate, and step-by-step operating instructions.

Operating Instructions for Innotech Maxim Digital Controllers

- ✓ Some of the paragraphs in Section 2 contain information and procedures which are of special importance to the user. To aid in their location, these paragraphs are identified by a tick in the page margin. An example of such a tick is shown in the margin next to this paragraph.

Section 3 of this instruction manual provides a description of the operating philosophy when configured for the Supervisor Mode, a detailed description of how the front panel controls and indicators operate, and step-by-step operating instructions to show the differences in the two modes of operation.

The Glossary of Terms in Section 4 is intended to ensure that the contents of this manual are clearly and easily understood by the reader. The glossary contains simple explanations of the technical terms used in the manual; explanations are given in non-technical language where possible.

Section 1 – Description

There are three controller versions, Maxim I which is standalone and Maxim II or Maxim III series, both of which can be networked with other Innotech Digital Controllers, and entire Genesis or Maxim product range.

Each Maxim type is available in the following configurations:-

MiniMax – Network capable

- no data logging or front panel display



Figure 1 : MiniMax

Maxim I – Standalone

- MAX1LD – has data logging and front panel display
- MAX1LN – has data logging but no front panel display



Figure 2 : Maxim I

Maxim II – Network capable

- MAX2LD – has data logging and front panel display
- MAX2LN – has data logging but no front panel display

Maxim I and II are visually very similar. The latter has network capability and therefore has a different download port.

Maxim III – Network capable

- MAX3ELD – has an Ethernet port, data logging and front panel display
- MAX3ELN – has an Ethernet port, data logging and no front panel display
- MAX3NLD – has no Ethernet port, data logging and front panel display
- MAX3NLN – has no Ethernet port, data logging and no front panel display



Figure 3 : Maxim III

1-1 What It Is

The Maxim Series Digital Controller is a state-of-the-art microprocessor (essentially a computer) packaged in a robust enclosure designed for mounting inside a switchboard. Just as any other computer, the unit contains its own internal memory for storing data and its internal operating program. The operating program is recorded into a non-volatile read-only memory (ROM); the ROM is non-volatile in that the operating program stored in it is not erased when the unit is turned off. Controls and indicators at the front panel permit manual operation of the unit; the controls and indicators are described in Section 2.

1-2 What It Does

The Maxim Series Digital Controller is designed mainly for automatic control of large scale heating, ventilation and air conditioning (HVAC) systems and any other system where autonomous control is required; operator action is mainly limited to monitoring tasks. The Maxim Series Digital Controller replaces older systems in which multiple analogue controllers were used for control of large HVAC systems. Also, the Maxim Series Digital Controller offers a number of features not provided by the controllers it replaces. The Maxim Series Digital Controller may be operated as standalone or within a Local Area Network (LAN) of Maxim Series Digital Controllers under the supervision of a process control management system. Operation of the Maxim Series Digital Controller in a LAN environment is covered in the Installation Instructions for Innotech Genesis Systems.

1-3 How It Does It

Figure 4 is a simplified block diagram of a typical HVAC system under the control of a Maxim Series Digital Controller. Input sensing devices in the various HVAC zones throughout the controlled area measure ambient conditions, such as temperature and humidity. The Maxim Series Digital Controller automatically monitors and processes these inputs from the sensors and produces output signals which control various HVAC devices such as heaters, fans, vents and air conditioning systems. Operation of the Maxim Series Digital Controller is fully automatic and is under the control of an internal operating schedule program into the unit.

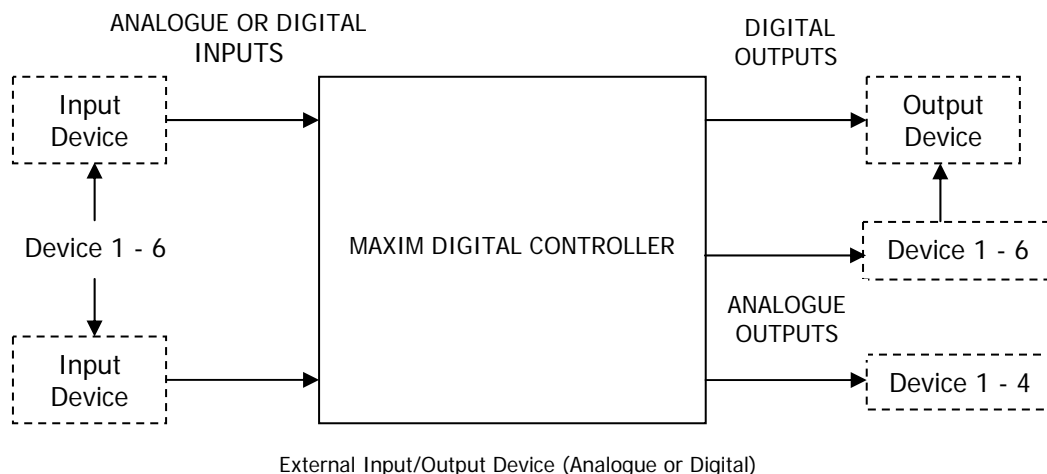

Figure 4 : Typical Application – Simplified Block Diagram

No expansion of the Maxim Series Digital Controller is possible; if this is required refer to the Genesis System manual for further details.

Input/output channels can be analogue and/or digital depending on the type of equipment involved. Input/output devices can be from Innotech's extensive line of field equipment or the devices can be acceptable user-provided items.

1-4 Maxim Configuration Software

Before being placed in service, the Maxim Series Digital Controller is "tailored" to its intended application by the Maxim Configuration (MaxCon) Software. Through the MaxCon Software, the user can actually design the Maxim Series Digital Controller's operating program. The designer uses the software to develop a functional block diagram, on a computer screen, of the entire HVAC system interconnected with the Maxim Series Digital Controller and containing all necessary operating values. When the design is completed, the software user loads the new configuration into the Maxim Series Digital Controller's ROM where it stays resident until such time as reprogramming may be necessary. In addition to establishing the specific operating configuration of the system, the MaxCon Software also sets up the following specific functions which can be monitored, used and/or changed by the Maxim Series Digital Controller operator:-

- System Operating Schedules, both weekly and yearly
- Access Codes defining what functions/data are available to an operator
- Organisation of monitoring data into logical groups (pages) for presentation to an operator
- Organisation of System Pages containing data of interest to supervisory personnel
- Visual alarms of system and processing faults
- Process values (setpoints)
- Logged Data (via laptop); Status or Value.

1-5 Setpoints

Setpoints are steady reference values against which a measured value is compared in the control process. Figure 5 is a simplified block diagram of how a temperature setpoint could be used for temperature control of a HVAC area. The control logic compares the difference between the output of the temperature sensor and the setpoint value. If the temperature is higher than the setpoint value, the cooling system is activated. If the temperature is below the setpoint value, the heating system is activated and if the temperature and setpoint values are equal, the heating and cooling systems are turned off.

The Max Con Software allows selected setpoints to be edited (changed) by an operator. Setpoints can be edited by the operation of front panel keys. How to edit setpoints is explained fully in Section 2.

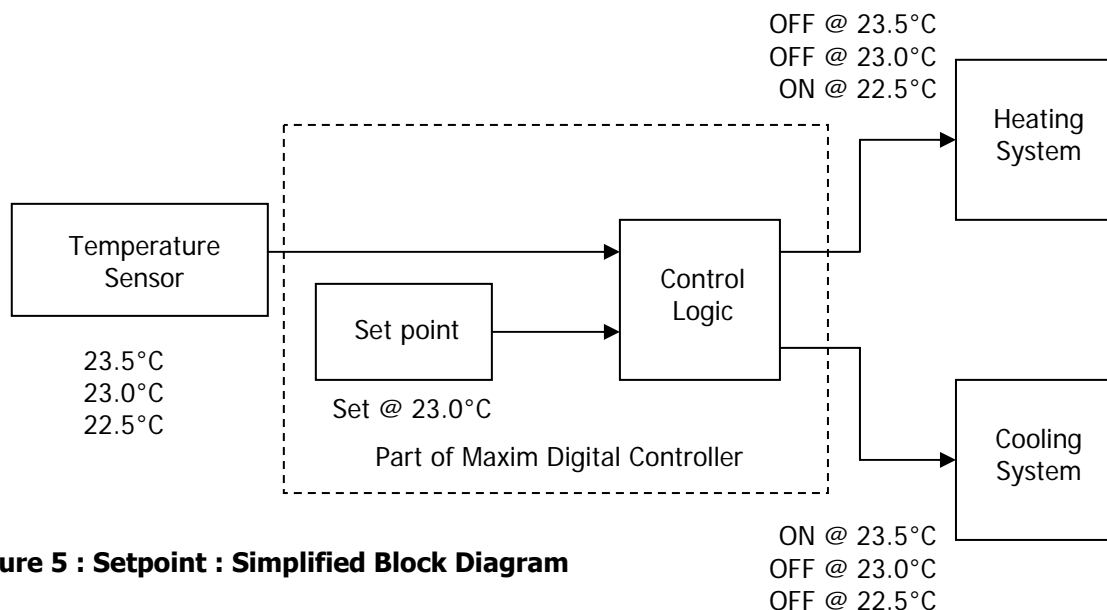

Figure 5 : Setpoint : Simplified Block Diagram

Section 2 – Operation

2-1 Introduction

The Maxim Series Digital Controller is designed as a versatile, easy-to-use, state-of-the-art microprocessor. It operates similar to, and contains several elements of, a typical personal computer (PC), including some of the operating keys.

The Maxim Series Digital Controller is configured for its specific application through use of the Innotech Maxim Configuration Software, either at the factory prior to delivery or by the customer after receipt of the equipment. Since each Maxim Series Digital Controller is configured to its own specific application, and since each application is unique, no two Maxim Series Digital Controllers are exactly alike in terms of detailed operating procedures. However, this is not a disadvantage since the Maxim Series Digital Controller is user-friendly and operation of the unit is simple, once the basic operational information is known. This section of the instruction manual provides the following information to familiarise the user with the operation of the Maxim Series Digital Controller:-

- An **Overview of Operation Information** required by the operator – this includes specific operation-related background information; such as descriptions of access levels, methods of accessing data, presentation formats and similar information necessary to the user's understanding of the Maxim Series Digital Controller's operational capabilities.
- A description of the Maxim Series Digital Controller's front panel **Controls and Indicators** – this includes detailed descriptions of what functions the various control keys perform and the significance of the indicator displays, especially the liquid crystal display (LCD) screen.
- **Detailed Operating Procedures** – building upon information covered in previous paragraphs, this part of the section guides the operator step-by-step through an operating scenario for a typical Maxim Series Digital Controller configuration.

NOTE

Some of the paragraphs in this section have been marked by a tick (✓) in the page margin. The ticks identify information or procedures which are of special importance to the operator.

Please note the screen displays used throughout are taken from a typical Maxim I Controller. Where these differ from the Maxim II or III is explained in the text.

2-2 Menu Structure

The LCD screen is the primary method by which Maxim Series Digital Controller output data is presented to the user. Other readout methods, such as through the Maxim Series software or by a modem, are available for monitoring data. However those methods are not within the scope of this manual, and therefore, are not included. This paragraph describes how LCD window readouts are organised into units called pages and the various types of information contained in those pages. More detailed information on the LCD readouts and LED indicator displays are contained elsewhere in this section. The structure of the LCD presentations is shown below and each section is described in the following paragraphs:-

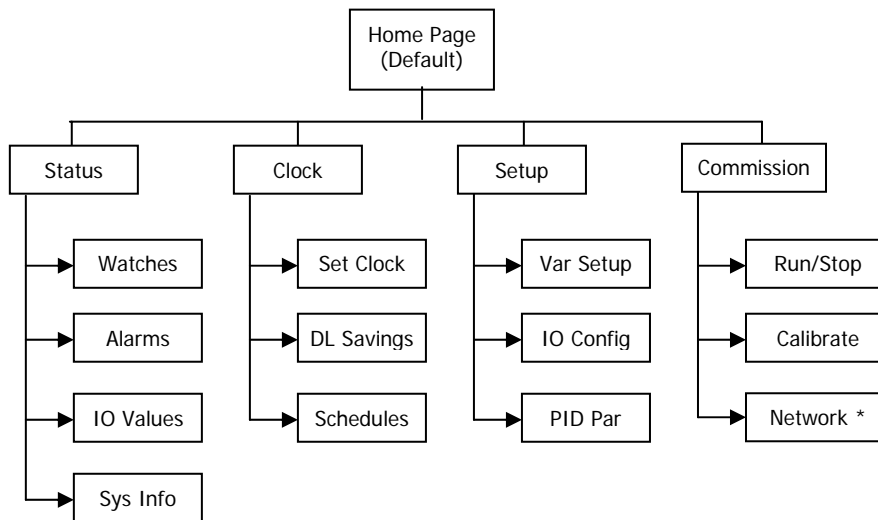
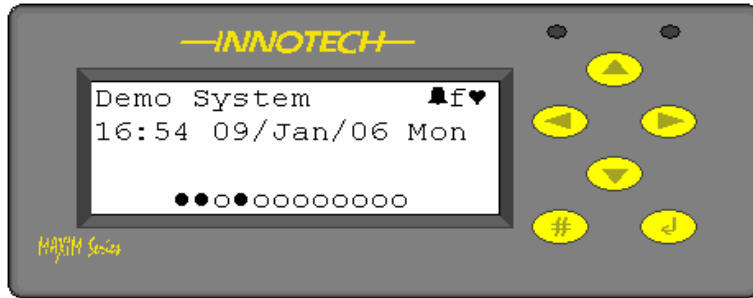

Figure 6 : Maxim Digital Controller Menu Structure

2-3 Home Page



The Home Page is the starting and ending point for operation of the Maxim Series Digital Controller. It is the first LCD presentations at start-up of the controller and it is the point at which a user logs on to the Maxim Series Digital Controller. The Home Page is also the point from which the user exits the system when operation is completed.

Figure 7 : Home Page Display







The LCD screen displays 4 lines of text, defined as follows:-

- Line 1 : is the name of the Maxim Series Digital Controller and is defined in the application program downloaded to the controller.
- Line 2 : shows the current time and date.
- Line 3 : can display Flash Watches which are simple messages caused by an action or operation within the controller. They are displayed on Lines 3 & 4 and conceal the virtual LED's.
To view the status of the LED's in these circumstances press the  button. A more detailed explanation is given in the next section. If Flash Watches are not programmed into the controller, the third line would be blank.
- Line 4 : shows the status of the controller's digital outputs. Maxim III has twelve (12) virtual LED's displayed; Maxim I and II each have six (6) virtual LED's displayed.

The keypad to the right of the LCD display allows the user access to the menu tree in the device and provides all the necessary key functions required to operate the controller.

The key pad functions are generally defined as follows:-

Keypad Functions –

-  Up – Moves cursor up / Increase – used to increase value (eg. say, a setpoint)
-  Down – Moves cursor down / Decrease – used to decrease value (eg. say a setpoint)
-  Left – Moves cursor left or pages to the left
-  Right – Moves cursor right or pages to right
-  Enter/Edit/Accept – moves down a menu level or allows a value to be changed and accepted
-  Exit/Esc – exits from a menu level, escapes changes (unless already saved via Enter button)

A key can have more than one function and this would be shown on the relevant screen when applicable and an example of this can be seen on the next page in the *Navigation* screen.

The icons and symbols that are displayed on the LCD screen from time to time are explained on the next page.

Operating Instructions for Innotech Maxim Digital Controllers

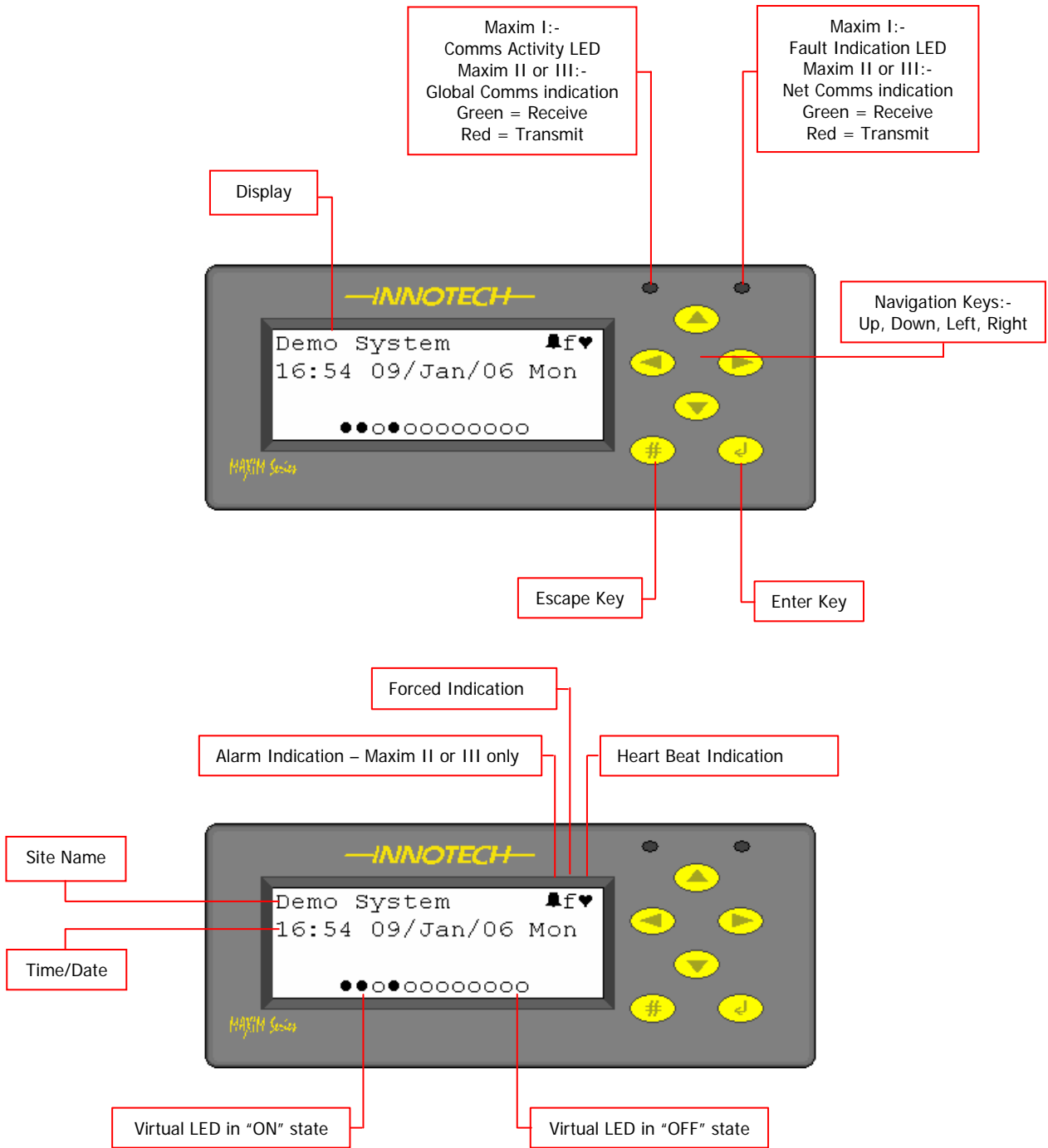

Figure 8 : Front Layout

2-4 Flash Page Watches

When the unit is first configured by the Maxim Configuration (MaxCon) software, watches can be assigned to a page of data called the Flash Page. If flash watches have been pre-configured, they are flashed on the third and fourth lines of the Home Page, at five second intervals. After start-up, the first Flash Watch is displayed for five seconds and then the next Flash Watch is displayed for five seconds, and so on until the cycle is repeated.

Alarms that have the *Display* option marked in the *block* are sent to the display as a flash. Alarm annunciation has priority and overrides the flash page until all alarms are cleared.

The figure below is an example of how Flash Watches are cycled on a typical Home Page.

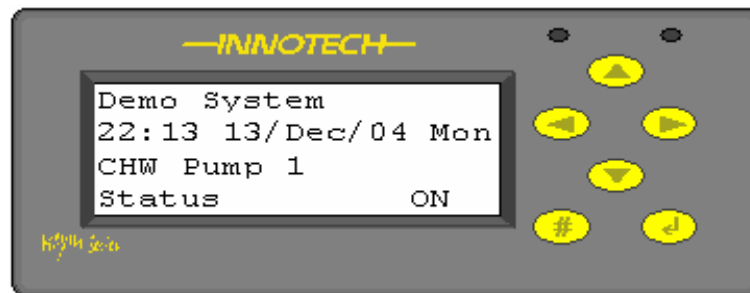

Figure 9 : Flash Page

The Flash Watch feature is especially useful for applications containing many watches; it allows the operator to monitor a range of specified watches without having to access a Watch Page and manually scroll through it. Depending on how the Flash and Watch Pages are configured by the software, an individual watch can be on the Flash Page and on a Watch Page as well. Watch data that would otherwise be editable can be displayed on a Flash Watch but cannot be edited from the Flash Watch.

The maximum numbers of Watches that can be displayed on a flash page are:-

- 5 for MiniMax / Maxim I / II Controllers
- 10 for Maxim III Controllers

2-5 Access Codes

When the controller is configured it is possible to prevent unauthorised access to any of the functions using Access Codes. These can only be set from within the MaxCon Software and are downloaded to the controller during commissioning. The default setting in MaxCon Software is OFF, which means that access codes are ignored. If access codes are enabled, there are two options:-

- *Only Supervisor code required* – If this option is selected access is allowed to the User level without any restrictions but to get to the Supervisor level the user has to enter the appropriate access code (Supervisor code).
- *Both User and Supervisor codes required* – If this option is selected access to both User and Supervisor level is allowed only after the appropriate access code is entered (User and Supervisor code respectively).

Default access codes – When a new configuration is created, MaxCon Software fills in two default access codes - one giving access to a User level, and the other giving access to a Supervisor level:-

- 0000 – User code
- 9999 – Supervisor code

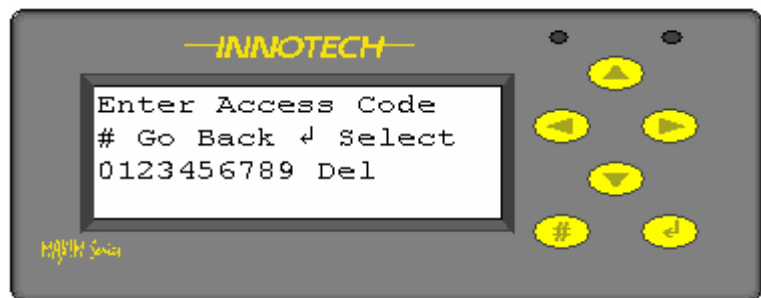

Figure 10 : Access Codes (1)

If the codes are not known, upload the program using the MaxCon software and they can be obtained from the *Config\Access Codes* menu option. Also, remember that access codes are disabled by default.

To enter the access codes, press any key when the Home Page is displayed and the access code screen is then displayed, above right.

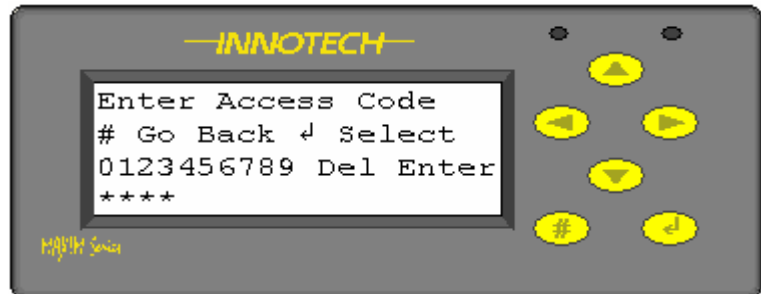

Figure 11 : Access Codes (2)







Use the  or  button to select the 4 digit code and as each number is highlighted press . An asterisk appears on the bottom line for each number entered. When all four numbers are entered correctly, press  again. If an incorrect code is entered, the display shows *Invalid Code* and time out after 5 seconds, returning to the Home Page.









Figure 12 : Access Codes (3)

If the correct code is entered, the display changes to the Navigate Screen. To change a code during entry highlight *Del*, and press  and the last number entered is removed. Press  again and the next number is removed and so on.

2-6 Navigation Page



Figure 13 : Navigate Menu

In this display the "Status" is flashing, this can be selected via  or another option can be selected by using , , ,  keys to move the cursor to the required position and then pressing .

During the session once logged ON, pressing the  button displays the "Navigate" screen allowing the operator to select the next function. Where lines 1 and 2 of the display provide advice on the key function. This is the starting point for the menu tree Figure 5 shown in section 2.2 and is the default screen when entering Supervisor Mode, explained in Section 3.0.

2-7 Status Menu

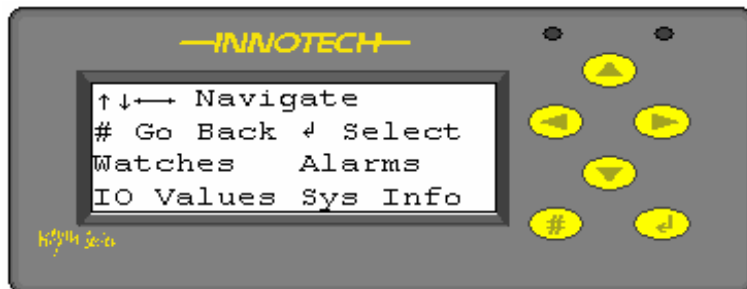









Figure 14 : Status Menu

Pressing  accesses the *Status* page of the controller and allows the user to scroll through the menu tree. In this display *Watches* is flashing.

Select this via  or choose another option using , , ,  buttons and press .

2-7-1 Status Menu – Watches



One of the features of the Maxim Series Digital Controller is the ability to display pages of information which can be accessed via the “Watches” option. Each page typically contains data to be monitored by the user (hence the term Watch Page) and process values, such as a controller setpoint, which may be viewed and edited.





Figure 15 : Typical Watch Page

The content of each page is normally arranged in a logical manner. For example, all the data on Watch Page 3 might represent parameters for Heating Zone 3 and the name of the particular Watch Page can be configured. So for the above example instead of -> *Page 1 ! Watch 1*, the page could be named *CHW Pumps*.

The arrangement and content of each Watch Page is programmed by the MaxCon configuration software. For that reason Watch Pages are unique to the controller for which they were configured. Representations of Watch Pages shown in this manual are typical examples only.

The controller Watches are accessed from the Home Page by pressing , select the Status option and press  again. This accesses the Status menu. Pressing  again accesses the Watch pages.

Above is an example of a typical Watch Page displayed at the LCD screen. A Watch occupies lines 3 & 4 of the page. In this sample page the **CHW Pump 1 Status** Watch is a monitored value or condition which cannot be edited by the user.

Using  button, the operator can move to the other Watch Pages, the designation of each page being shown in the top left hand corner of the screen. When the correct page has been reached, the  or  buttons allow the operator to move between the Watch's on that page.

The **LCHW Temp Setpoint** Watch to the right is a process value that can be edited by the user. This value can be edited through the use of front panel controls. Watches that can be edited by the operator are identified by the extra command that appears on the 2nd line, ' ↓ Edit'.

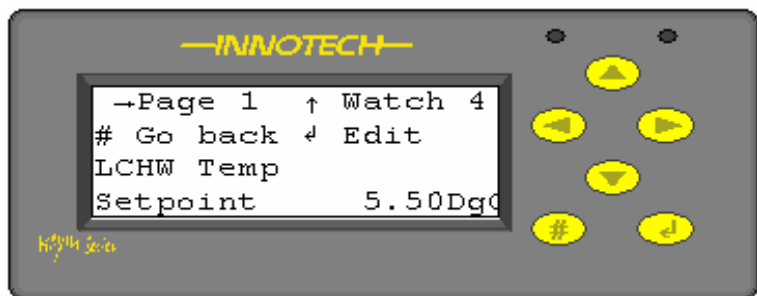

Figure 16 : Typical Adjustable Watch Value

The maximum numbers of Pages/Watches that can be displayed on a controller are:-

- 5 Pages and 5 x Watches/Page : MiniMax, Maxim I and II Controllers
- 8 Pages and 10 x Watches/Page : Maxim III Controllers

2-7-2 Status Menu – Alarms

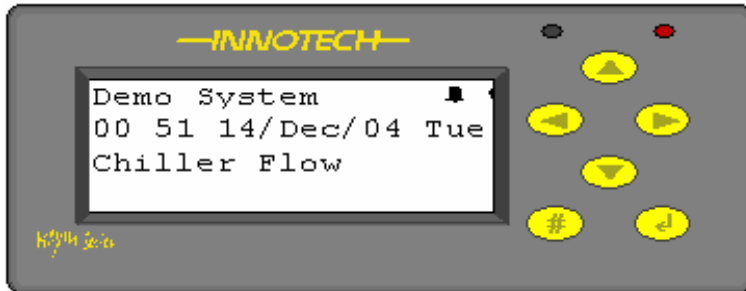

Figure 17 : Typical Flash Page Alarm

Alarms can be included in the application program and, depending how these have been configured, when activated, will either appear constantly on the display or if other alarms are present are rotated every 5 seconds. The maximum number of alarms that can be placed in a configuration is:-

- MiniMax – 16 per device
- Maxim I / II – 16 per device
- Maxim III – 32 per device

On the Flash Page the presence of an alarm is indicated by the Alarm LED flashing and an Alarm symbol appearing in the top right hand corner of the display. The alarm message, configured in the alarm block, is shown on the 3rd and 4th line of the display.

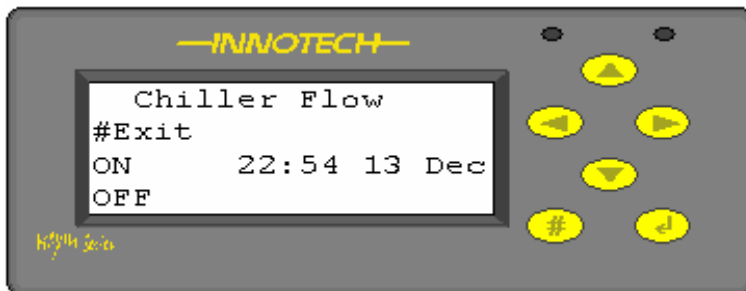

Figure 18 : Typical Alarm Page

Alternatively, using the specific Alarms page, found under the menu option *Status/Alarms*, the active alarms can be displayed as shown right. Line 1 shows the *Alarm Message*, Line 2 is the *Key commands* associated with the page, Lines 3 & 4 display the time/date the alarm was started and stopped.

2-7-3 Status Menu – IO Values

The IO Values screen can be used to display the values directly at the inputs and outputs of the controller. It is not necessary to have an application program downloaded to view these values.

The first page displayed is Universal inputs used to display the values directly at the inputs and outputs of the controller.

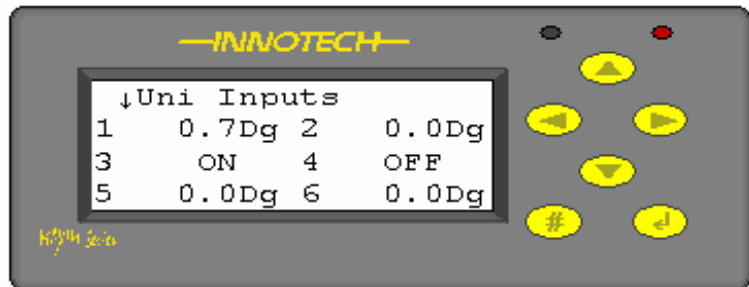





Figure 19 : Universal Inputs Page

Use  to view the other two pages and  to return to the previous menu. It is not necessary to have an application program downloaded to view these values. The first page to be displayed is the Universal inputs, use  to view the other two pages and  to return to the previous menu.

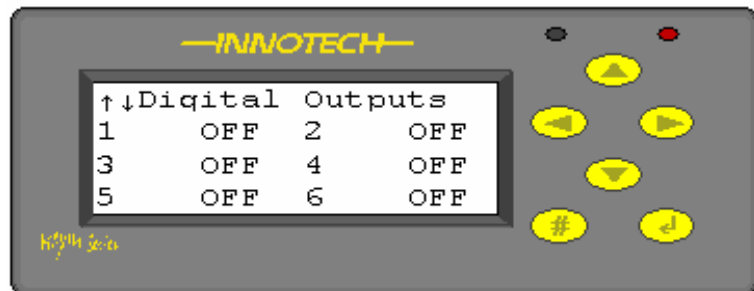

Figure 20 : Digital Outputs Page

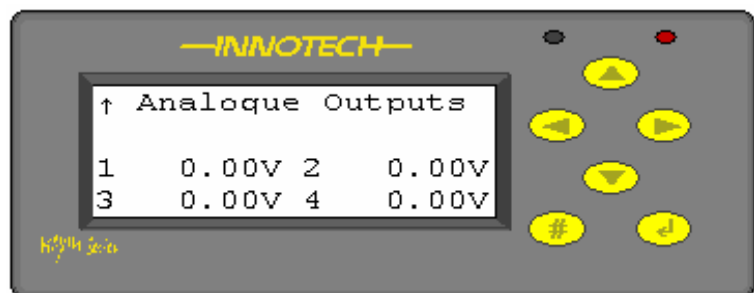

Figure 21 : Analogue Outputs Page

2-7-4 Status Menu – System Info

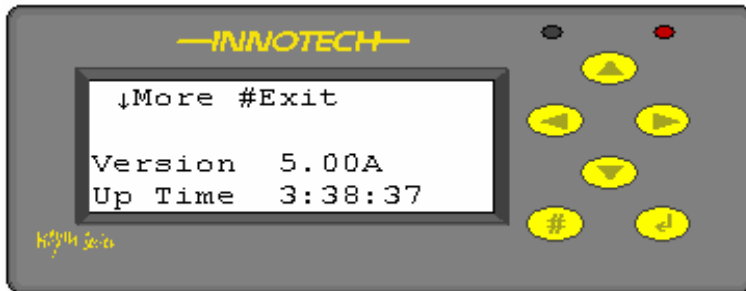



Figure 22 : System Information (1)

The *Sys Info* screens display information about the controller and are useful in terms of diagnostics to find out what type of controller it is, what firmware version is fitted and so on.

Screen 1 displays the firmware version and the time the controller has been running since the last power cycle.

Use  and  buttons to move between the displays and return to the previous display as required.

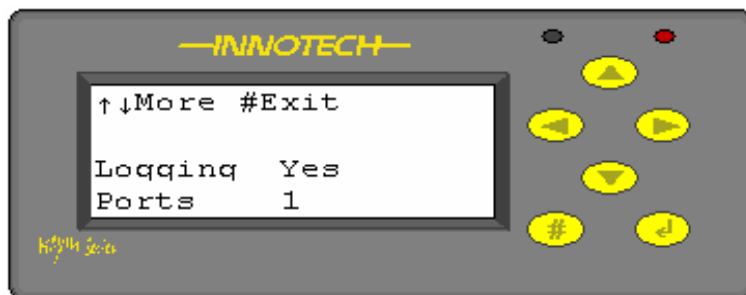

Figure 23 : System Information (2)

Screen 2 shows whether the device is capable of performing data logging or not and also displays the number of communications ports. In this particular case the controller has logging capability but only one port; if a display is fitted it would be a Maxim *MAX1LD* type.

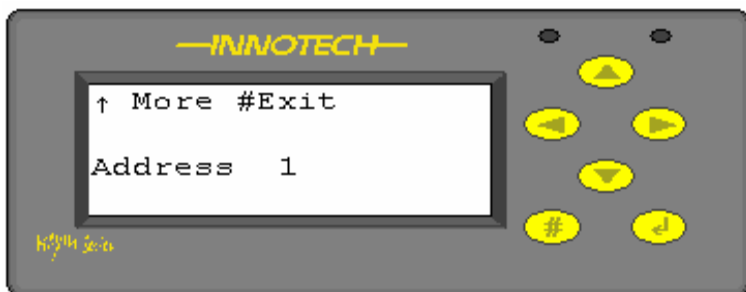



Figure 24 : System Information (3)

Screen 3 shows the Network address of the device. In the case of the Maxim I device this is always "1".

If a Maxim II or III device is being used this could be between 1 and 128.

2-8 Clock – General

From the Home Page, press

 button to enter the Navigate

screen. Use , , ,

 buttons to select the *Clock* menu option which should be flashing and



then press  again. The Set Clock option is now flashing.



Figure 25 : Clock Menu

Three menu options are now displayed:-

- Set Clock – allows the operator to reset the current Time/Date
- DL Saving – allows the operator to reset the Summer/Winter start and stop times
- Schedule – allows the operator to adjust the *Weekly* or *Yearly* plant Schedules

Use the arrow keys to select the required option which then flashes. Now press 

✓ Notes:

Controllers are set (ex.factory) to Australian time and may be 9 hours ahead of UK time. It is important to reset the clock as soon as practical.

MiniMax - schedule blocks can be incorporated into a MiniMax application but the controller does not have an internal RTC chip. It relies on getting a time synch pulse from the network master (a Maxim II or III device at address 1) to reset the MiniMax internal counter. The synch pulse is sent both when the device at address 1 is powered up and at 3.00am. It is also requested when a Minimax powers up. The counter will only be reset if it differs by more than 60 seconds from the synchronised time.

2-8-1 Clock – Set Clock

Select the Set Clock option to display System Time, right. Use steps 1-6 below to adjust Time/Date settings.









1. Press  to display the time/date change screen as shown above.
2. Press  again and the "Hrs:" starts flashing.



Figure 26 : System Time/Date

3. Press  or  buttons to select the value to edit. The flashing text indicates what has been selected to edit.
4. Then use ,  to change the value.
5. Repeat steps 1-4 for the rest of the displayed values until the correct Time / Date is displayed.
6. Press  to save or  to abort the changes.
7. Finally, press  several times until the Home Page is displayed.

2-8-2 Clock – DL Saving Start/Stop



Figure 27 : DL Saving Status

After selecting the DL Saving option the DL Saving Status display, left, is shown. Use the steps 1-6 below to adjust the Start Time.

Use the or buttons to select either the Status, Start or Stop screens depending on the action required.

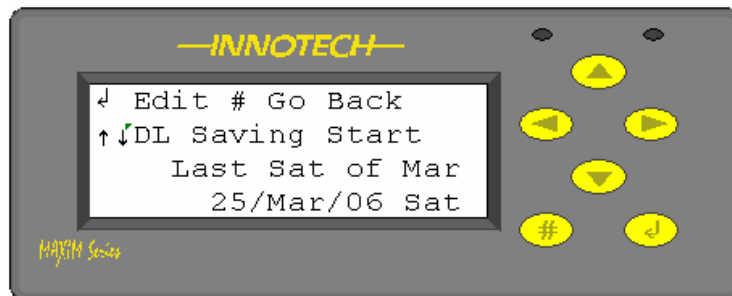

Figure 28 : DL Saving Start

The Daylight Saving Start operation is determined by specifying the occurrence, *First, Second, Third, Fourth or Last*; the Day of the week, *Mon – Sun*, and the Month, *Jan - Dec*

When this has been specified, the program will calculate the date of the next event which changes annually.



Figure 29 : DL Saving Stop

The Daylight Saving Stop operation is determined in the same manner as the Start operation

When this has been specified, the program will calculate the date of the next event which changes annually.

1. Press and *Enabled* starts flashing. Press or buttons to select the required status, press to accept.
2. Press or buttons to change to the DL Saving Start display.
3. Press and *occurrence* starts flashing. Use or buttons to select.
4. Press or buttons to move to *Day* and use or buttons to select.
5. Press or buttons to move to *Month* and use or buttons to select.
6. Press and the DL Saving Start date will be calculated automatically.
7. Use or buttons to change to the DL Saving Stop menu and repeat steps 3-6
8. Finally, press several times until the Home Page is displayed.

✓ Note: The default Daylight saving time is a Universal Time offset of 1 hour and cannot be changed.

2-8-3 Clock – Schedule

After selecting the Schedule option the Schedule Edit display, right, is shown. Use the steps shown to the right to adjust the required schedules. Users should note that although the switch times within a schedule block can be added to, edited or deleted through the keypad and display, the actual schedule itself cannot be deleted from or new ones added, to the program.



Figure 30 : Schedule Edit

The application program can have three types of Schedules programmed:-

- The Daily Schedule block performs the function of a daily time clock. Over a one day time period, you are able to specify up to 8 START/STOP pairs with a resolution down to a minute, this is then repeated every day.
- The Weekly Schedule block performs the function of a seven day time clock. Over a seven day time period, you are able to specify up to either 16 or 32 START/STOP pairs (depending on the primary device selected) with a resolution down to a minute. The maximum number of START/STOP pairs allowed on the Maxim I and II Controllers is 16 and on the Maxim III Controller is 32.
- The Exception Schedule block (referred to as *Yearly* on Maxim displays) provides an override function for system control. The schedule can contain up to the maximum number of time periods allowed (depending on the primary device selected) individual time periods setting an output value state to ON or OFF over a 365 day period (366 in leap years). The maximum number of time periods allowed on the Maxim I and II Controllers is 16 and on the Maxim III Controller is 32. The exception schedule itself may be overridden with an input, so that you can chain together multiple exception schedules as necessary.

2-8-3-1 Clock – Schedule – Daily – Add



Figure 31 : Daily Add/Edit/Del

Selecting the Daily, Weekly or Yearly options allows the operator to **Add**, **Edit** or **Delete** an existing schedule times and/or dates. A typical screen display is shown left.

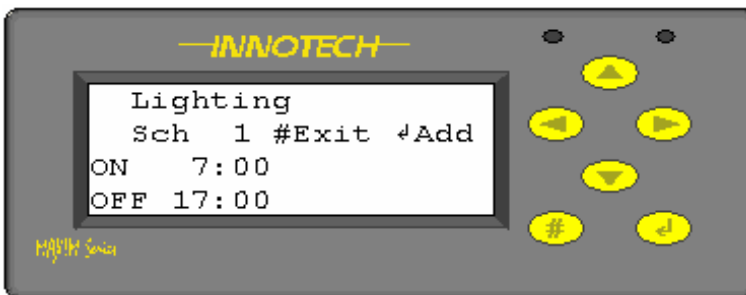

Figure 32 : Daily Schedule Add (1)

Select the *Daily/Add Daily* menu option and press and the Daily Schedule Add screen is displayed.

Use or buttons to select the schedule to which a new switch time is to be added.

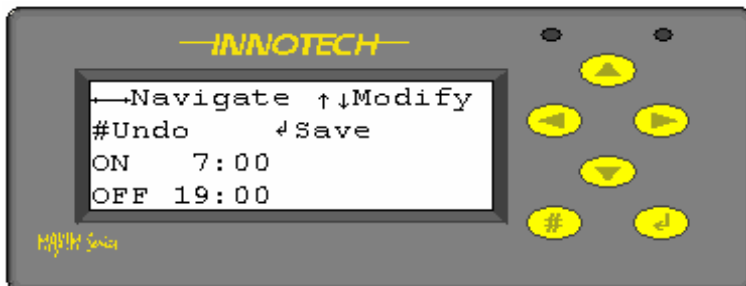

Figure 33 : Daily Schedule Add (2)

Press again and the ON time begins to flash.

Following the instructions below to Add a new switch time to the Daily schedule block.

1. Press again and the ON time begins to flash.
2. Use or buttons to change the time.
3. Use or buttons to select the *ON* or *OFF* times and the respective *hours* or *minutes* to be changed.
4. At each point the selected value flashes.
5. Once the correct time has been set up, press to save or to undo the changes.

The new switch times will not be displayed in this screen area. To check if the times have been set correctly return to the Daily/Edit menu option and scroll through the switch times with the and buttons.

2-8-3-2 Clock – Schedule – Daily – Edit

Selecting the Daily, Weekly or Yearly options allows the operator to **Add**, **Edit** or **Delete** an existing schedule times and/or dates. A typical screen display is shown right.

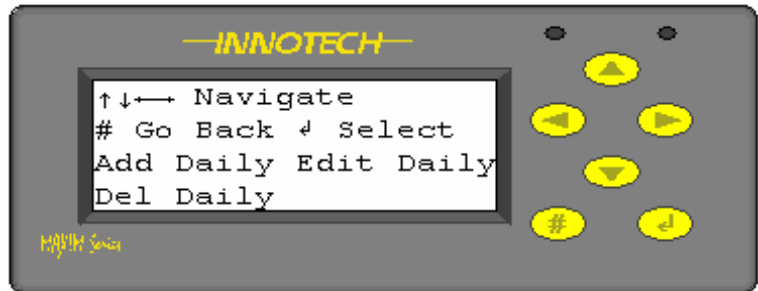

Figure 34 : Daily Add/Edit/Del

Select the *Daily/Edit Daily* menu option and press and the Daily Schedule Edit screen is displayed, right.

Use the or buttons to select the Schedule that has the switch times to be changed.



Figure 35 : Daily Schedule Edit (1)

Press again and the ON time begins to flash, right.

Following the instructions below to Edit an existing switch time in the *Daily* schedule block.

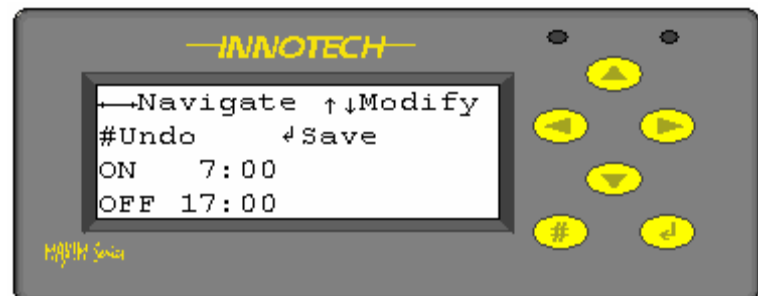

Figure 36 : Daily Schedule Edit (2)

1. Press again and the ON time begins to flash.
2. Use or buttons to change the time.
3. Use or buttons to select the *ON* or *OFF* times and the respective *hours* or *minutes* to be changed.
4. At each point the selected value is flash.
5. Once the correct time has been set up, press to save or to abort the changes.

2-8-3-3 Clock – Schedule – Daily – Delete



Selecting the Daily, Weekly or Yearly options allows the operator to **Add**, **Edit** or **Delete** an existing schedule times and/or dates. A typical screen display is shown left.



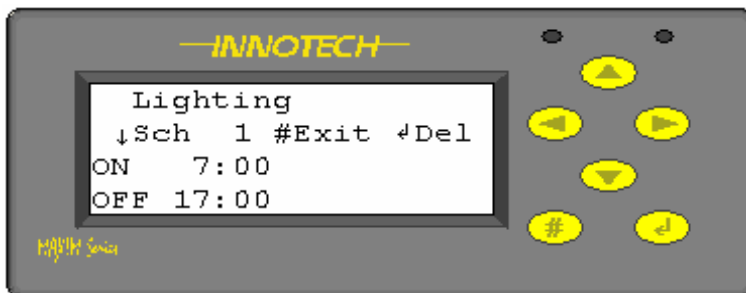



Figure 37 : Daily Add/Edit/Del



Select the *Del Daily* menu option and press , the Daily Schedule *Del* screen is displayed, left.

Follow the instructions below to delete an existing switch time in the Daily schedule block.

Figure 38 : Daily Schedule Delete

1. Use the  or  buttons to select the Schedule to edit.
2. Use  or  buttons to select the switch time to delete.
3. Press  to delete the selected time.
4. Press  to return to the previous menu.

✓ **Note:** There is no “undo” function. If a switch time is deleted by mistake it is have to be re-entered using the “ADD” function.

2-8-3-4 Clock – Schedule – Weekly – Add

Selecting the Daily, Weekly or Yearly options allows the operator to **Add**, **Edit** or **Delete** an existing schedule times and/or dates. A typical screen display is shown right.



Figure 39 : Weekly Schedule

Select the *Add Wkly* menu option and press and the Weekly Schedule Add screen is displayed.

Use or buttons to select the schedule which has the switch times to be changed.

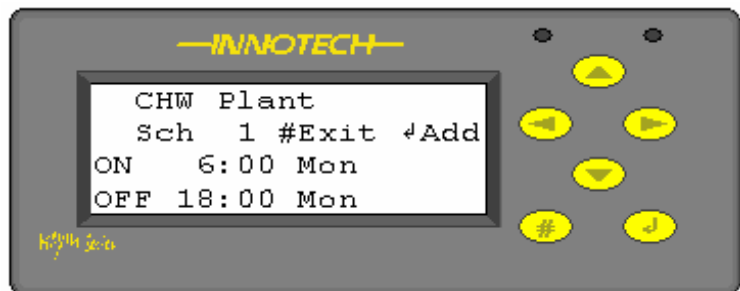

Figure 40 : Add Weekly Schedule (1)

Press again and the ON time begins to flash.

Follow the instructions below to Add a new switch time to the Weekly schedule block.

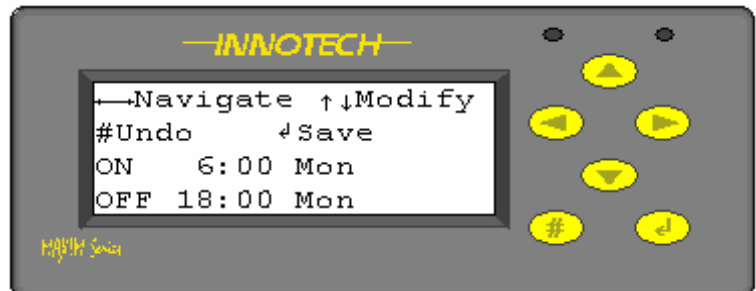

Figure 41 : Add Weekly Schedule (2)

1. Press again and the ON time begins to flash.
 2. Use or buttons to change the time.
 3. Use or buttons to select the *ON* or *OFF* times and the respective *hours* or *minutes* to be changed.
 4. At each point the selected value will flash.
 5. Once the correct time has been set up, press to save or to abort the changes.
- Once a new weekly event has been added and saved it can no longer be edited in this menu.

✓ **Note:** Press to move up a menu level and select the *Edit Wkly* menu option. Also be aware the 7 day clock starts on Sunday morning (00:00) and finishes on Saturday night (00:00).

2-8-3-5 Clock – Schedule – Weekly – Edit



Selecting the Daily, Weekly or Yearly options allows the operator to **Add**, **Edit** or **Delete** an existing schedule times and/or dates. A typical screen display is shown left.

Figure 42 : Weekly Schedule

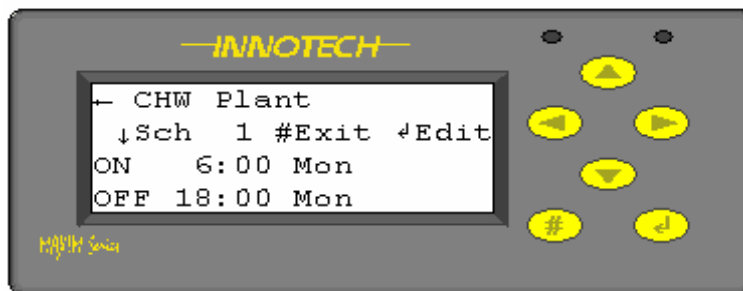

Select the *Wkly / Edit Wkly* menu option and press  and the Weekly Schedule Edit screen is displayed.





Use the  or  buttons to select the Schedule to edit.





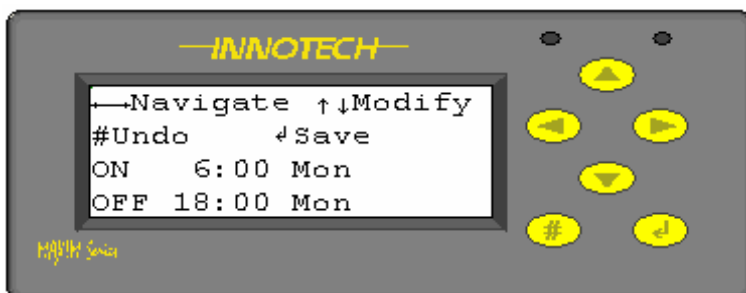

Figure 43 : Weekly Schedule Edit (1)



Press  again and the ON time begins to flash.

Following the instructions below to Edit an existing switch time in the *Wkly* schedule block.

Figure 44 : Weekly Schedule Edit (2)

1. Press  again and the ON time begins to flash.
2. Use  or  buttons to change the time.
3. Use  or  buttons to select the *ON* or *OFF* times and the respective *hours*, *minutes* or *Day* to be changed.
4. At each point the selected value will flash.
5. Once the correct time has been set up, press  to save or  to abort the changes.

2-8-3-6 Clock – Schedule – Weekly – Edit – 24hr Operation

Navigate to the Schedule/Weekly/Edit screen displayed left and then follow the instructions given below.

To change a schedule to enable a plant 24hrs a day follow the steps outlined below.

Select the *Wkly / Edit Wkly* menu option and press  and the Weekly Schedule Edit screen is displayed on the right.

Press  again and the ON time begins to flash, right.

Following the instructions below to Edit an existing switch time in the *Wkly* schedule block, the example given is for 24hr operation on a Sunday.



Figure 45 : Weekly Schedule (24hr)

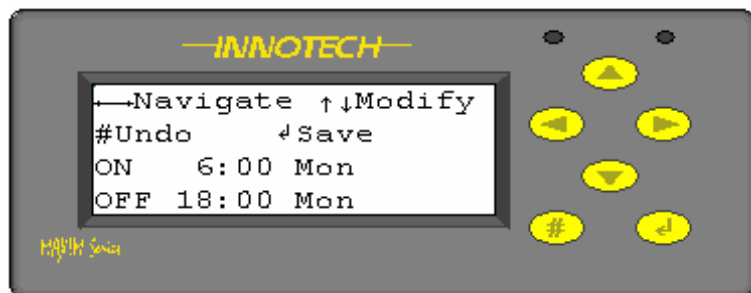













Figure 46 : Weekly Schedule Edit (24hr Operation)

1. Press , the "ON" hrs should flash, then press  and change the time to "00:00".
2. Press , the "Day" should flash, then press  or  to change it to "Sun".
3. Press , the "OFF" hrs should flash, press  and change the time to "00:00".
4. Press , the "Day" should flash, press  or  to change it to "Mon".
5. Press  to save. The display should be as shown below.

✓ **Note:** It is important to realise the 7 day clock starts 00:00 Sunday morning and finishes 00:00 Saturday night. So the direction in which the time is adjusted is important. So make sure the instructions listed above are followed.

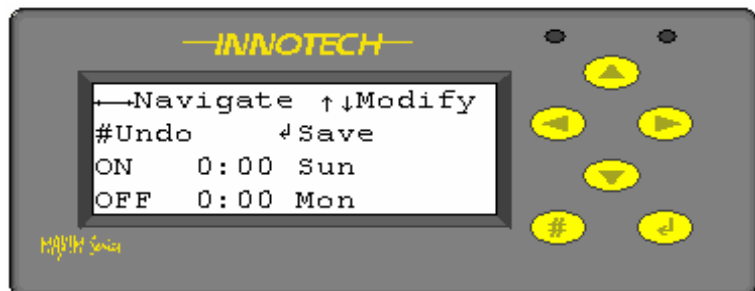

Figure 47 : Weekly Schedule Edit (24hr)

2-8-3-7 Clock – Schedule – Weekly – Delete



Figure 48 : Weekly Schedule

Selecting the Daily, Weekly or Yearly options allows the operator to **Add**, **Edit** or **Delete** an existing schedule times and/or dates. A typical screen display is shown left.

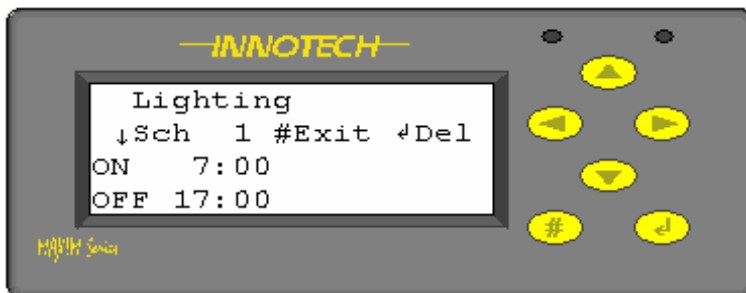











Figure 49 : Weekly Schedule Delete

Select the *Wkly / Del Wkly* menu option and press  and the Weekly Schedule Delete screen is as displayed on left.

Use the  or  buttons to select the Schedule to edit and follow the instructions below.

1. Use the  or  buttons to select the Schedule to edit.
2. Use  or  buttons to select the switch time to delete.
3. Press  to delete the selected time.
4. Press  to return to the previous menu.



Note: There is no “undo” function. If a switch time is deleted by mistake it will have to be re-entered using the “ADD” function.

2-8-3-8 Clock – Schedule – Yearly – Add

Selecting the Daily, Weekly or Yearly options allows the operator to **Add**, **Edit** or **Delete** an existing schedule times and/or dates. A typical screen display is shown right.



Figure 50 : Yearly Schedule

Select the *Add Yrly* menu option and press  and the Yearly Schedule Add screen is displayed, right.

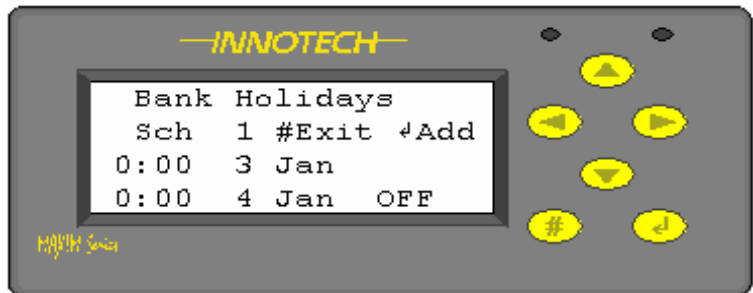



Figure 51 : Add Yearly Schedule (1)

Press  again and the display will change to show the current time/date as the new start/stop times, right. The *Hrs* on line 3 starts flashing.

Follow the instructions below to Add a new switch time to the Yearly schedule block.

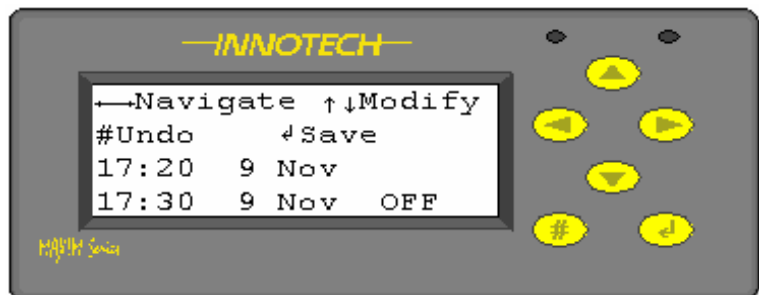









Figure 52 : Add Yearly Schedule (2)

1. Use  or  buttons to change the time/date.
2. Line 3 represents the time/date the schedule will start.
3. Line 4 represents the time/date will stop and also the override condition, in the case above, OFF.
4. Use  or  buttons to select the respective *hours, minutes, day, month, override condition* to be changed.
5. At each point the selected value will flash.
6. Once the correct values have been set up, press  to save or  to abort the changes.



Note: These operations are relative to an existing Yearly schedule and cannot be used to add a new schedule block to the program. Also, once a new exception event has been added and saved it can no longer be edited in this menu.

Press  to move up a menu level and select the *Edit Yrly* menu option.

2-8-3-9 Clock – Schedule – Yearly – Edit

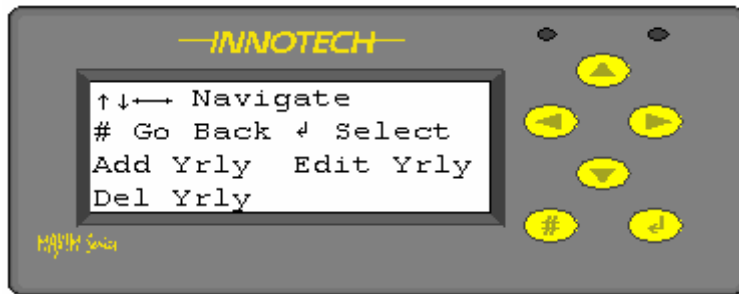

Figure 53 : Yearly Schedule

Selecting the Daily, Weekly or Yearly options allows the operator to **Add**, **Edit** or **Delete** an existing schedule times and/or dates. A typical screen display is shown left.

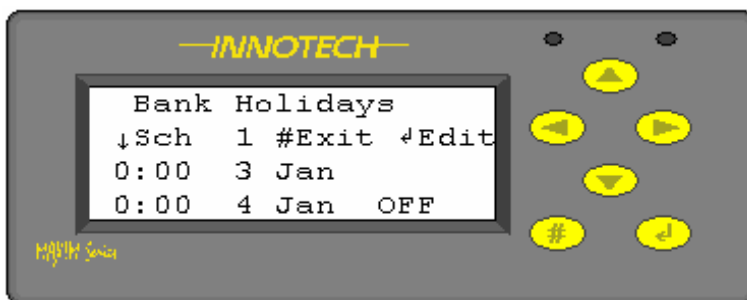

Figure 54 : Yearly Schedule Edit (1)

Select the *Edit Yrly* menu option and press **↵** and the Yearly Schedule Edit screen is displayed, left.

Use the **←** or **→** buttons to select the Schedule to *Edit*.

Use **↑** or **↓** buttons to select the switch time to *Edit*.

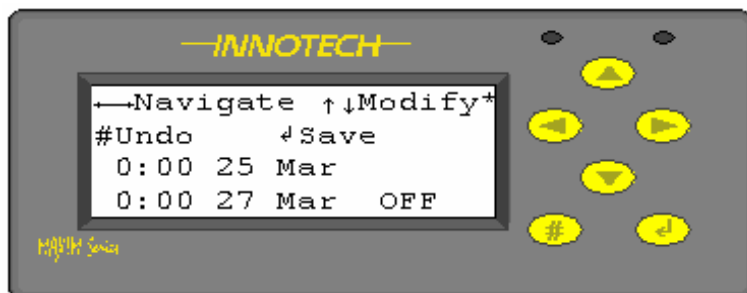

Figure 55 : Yearly Schedule Edit (2)

Following the instructions below to *Edit* an existing switch time in the *Yrly* schedule block.

1. Use **↑** or **↓** buttons to change the time.
2. Use **←** or **→** buttons to select the respective *hours, minutes, day, month, override condition* to be changed.
3. At each point the selected value will flash.
4. Once the correct time has been set up, press **↵** to save or **#** to abort the changes.



2-8-3-10 Clock – Schedule – Yearly Delete

Selecting the Daily, Weekly or Yearly options allows the operator to **Add**, **Edit** or **Delete** an existing schedule times and/or dates. A typical screen display is shown right.



Figure 56 : Yearly Schedule

Select the *Yrly / Del Yrly* menu option and press  and the Yearly Schedule Delete screen is displayed, right.

Use the  or  buttons to select the Schedule to edit and follow the instructions below.

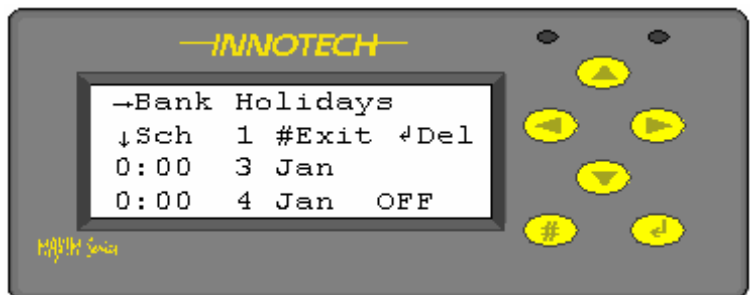







Figure 57 : Yearly Schedule Delete

1. Use the  or  buttons to select the Schedule to edit.
2. Use  or  buttons to select the switch time to delete.
3. Press  to delete the selected time.
4. Press  to return to the previous menu.

✓ Note: There is no “undo” function. If a switch time is deleted by mistake it will have to be re-entered using the “ADD” function.

2-9 Setup – General

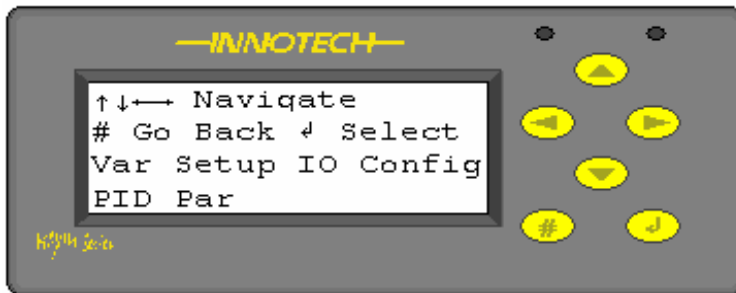

Figure 58 : Setup Menu

Select this via or choose another option using , , , buttons and press .

From the Home Page

press button to display the “Navigate” screen, press and to display the Setup menu.

In this operating mode the setup can only be viewed and not in any way amended.

In this display *Var Setup* is flashing.

2-9-1 Setup – VAR Setup



Figure 59 : Variable Setup (1)

However, *watches* such as analogue or digital setpoints can have their *Edit* command set to “Y” as in the case below, or “N”.

This series of screen displays allows the user to page through the *Watches* that have been configured for the controller.

Watches that are configured as status points or measured values cannot be changed and the *Edit* command, (bottom left) is set to “N”.



Figure 60 : Variable Setup (2)

This is a simple way of preventing unauthorised access to key setpoints and other variable parameters.

If EDIT = “Y”, it allows the user to change the value from the keypad from within the *Status/Watches* display at the normal user or default access level.

If EDIT = “N”, the user cannot change the value unless they logon to the controller in Supervisor Mode from the *Home* Page.



Note: The value of the Edit command can only be adjusted in Supervisor Mode.

2-9-2 Setup – IO Config

This series of screen displays show the user the following information. The information displayed is read only.

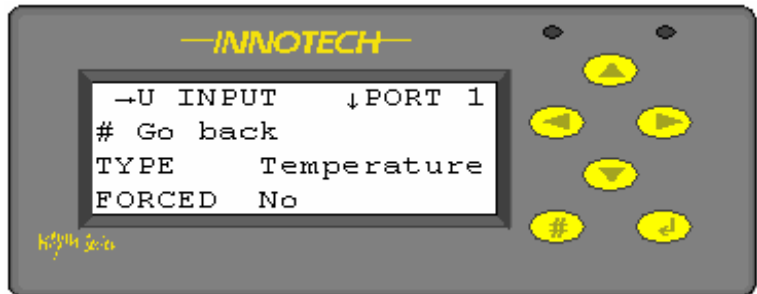

Figure 61 : IO Config Display (1)

Line 1 – defines the input type and the terminal number, in the above case, Universal Input #1.

Line 2 – is a menu command and allows the user to return to the previous page.

Line 3 – defines the input type, in this case a measured value, Temperature.

Line 4 – defines whether the output has been *forced* (ie. manually overridden).

The screen display right, shows the same Universal Input, but this time the value has been overridden, so the command Forced = "Y".

The figure, right, is the value that the input has been "forced" to, in this case, 5.2degC.

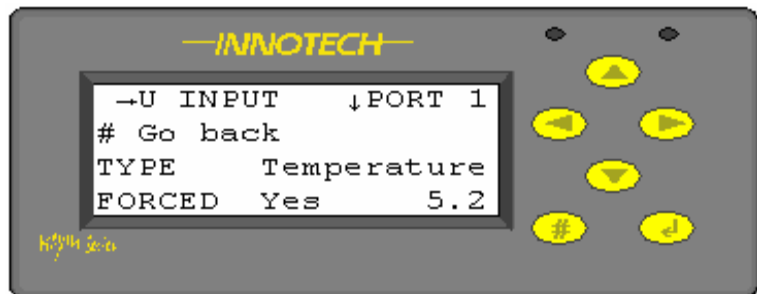

Figure 62 : IO Config Display (2)

A typical analogue output which has been forced or manually overridden is shown right. The output is a 0-10V analogue signal on AO#1.

In this case it has been forced or overridden to 6.0V.

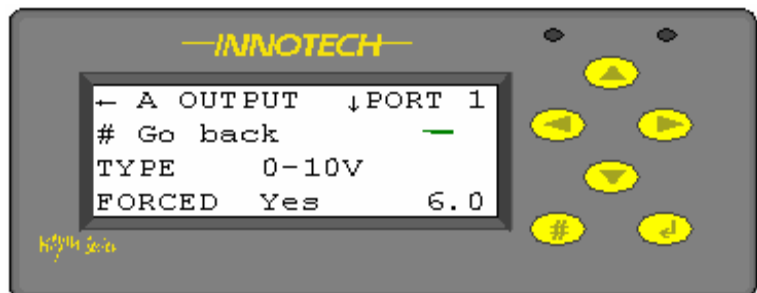

Figure 63 : IO Config Display (3)

✓ **Note:** As mentioned earlier these screens are read-only and are accessible at the default user level. For access to modify the values, change or cancel forced inputs and outputs back to automatic control etc, the user will need to have the correct access level and logon to the Supervisor Mode.

2-9-3 Setup – PID PAR

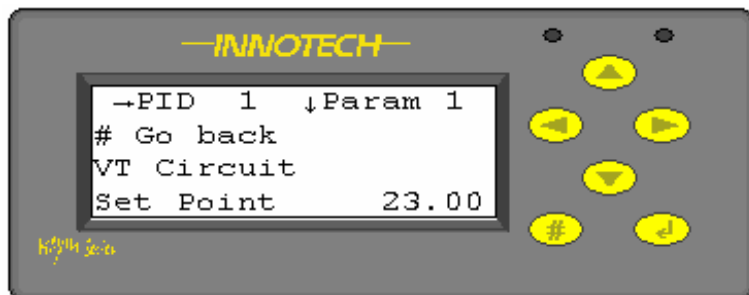

Figure 64 : PID Parameter



This series of screen displays show the user the internal block values for any PID control loops used within the software configuration of the controller. The information displayed is read only.

The PID Loop block is a twin output proportional plus integral and derivative control loop. It is one of the primary control blocks used for maintaining constant temperature, humidity or controlled variable.

Line 1 – defines the PID block number, in the above case we are looking at PID Loop #1

Line 2 – is a menu command and allows the user to return to the previous page

Line 3 – defines the block name, in this case *VT Circuit*.

Line 4 – defines the internal setpoint, *23.00*. Use the ,  buttons to display the other internal block values and settings, these are listed below:-

- *Setpoint* – This is the setpoint of the PID Loop to which the input to the block should finally settle, which is used only if the **SETPOINT** input to the block is not connected to a **User Variable**. This does not have to be connected, but doing so allows the setpoint to be modified (via an Editable Watch on a User Variable) during Maxim operation.
- *Dead Band* – This is the total range of the Dead Band for the PID Loop. This is the range of values (centred about the Setpoint) in which no Direct or Reverse acting control is used.
- *Alpha* – This is a smoothing constant (percentage) used in the integral and derivative calculations for the block. It is a representation of how fast the output value will change to meet the required value. An alpha of 100% will change immediately to the required value, whereas an alpha of 50% will only move half way toward the required value each time the block is processed. Note: If Alpha is set to 0% the block behaves the same as if it was set to 100% (otherwise the block output value would never change).
- *Direct P* (also *Direct I* and *Direct D*) – This group of fields provides for the setting of the Proportional Band range for the PID control loop as well as fine tuning of the derivative and integral constants for the calculation for the direct acting part of the PID Loop.
- *Reverse P* (also *Reverse I* and *Reverse D*) – This group of fields provides for the setting of the Proportional Band range for the PID control loop as well as fine tuning of the derivative and integral constants for the calculation for the reverse acting part of the PID Loop.

2-10 Commission







From the Home Page press the  button to display the "Navigate" screen. Use the , , ,  buttons to select the *Commission* function and then press  again. The information displayed is read only.



Figure 65 : Commission Menu Display

2-10-1 Commission – Run/Stop

The *Run/Stop* function allows the controller processor to be stopped and started as required. When in the *Stopped* mode processing is suspended and the controller is effectively switched off (ie. analogue outputs would be *OV*, digital outputs would be *Off*). The state can only be changed in the Supervisor mode of operation.



Figure 66 : Run/Stop Menu Display

This function is extremely useful. It allows a controller to be pre-programmed prior to despatch but putting it into the *Stopped* mode allows it to be powered on site in a safe state. Once all the commissioning checks have been carried out and the user is satisfied all external devices have been correctly connected and configured, changing the state to Running then allows the application program to run.

2-10-2 Commission – Calibrate

The *Calibrate* function allows the user to view the analogue inputs and see if the signal has been adjusted to take into account any variance in cable resistance or sensor calibration.

Press the ,  buttons to page through the inputs.

The calibration can only be changed in the Supervisor mode of operation.

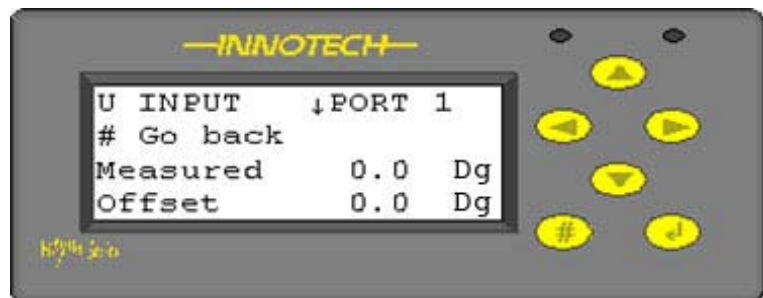

Figure 67 : Calibrate Menu Display

2-10-3 Commission – Network

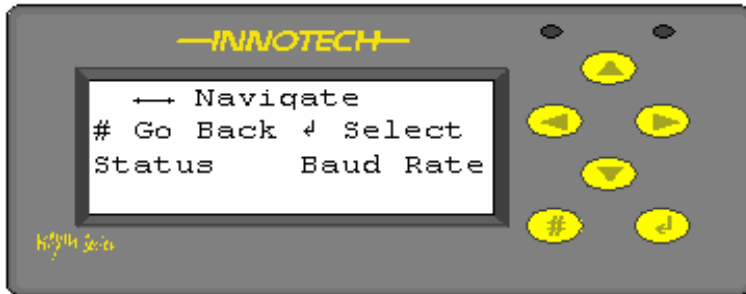



Figure 68 : Network Menu Display

From the *Commission* page select *Network* and press the  button to display the screen left. The information displayed is read only.

2-10-3-1 Commission – Network – Status

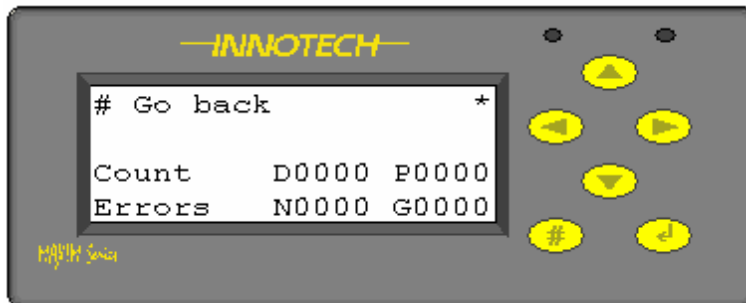



Figure 69 : Network Status Display

From the *Network* display menu select *Status* and press .

It is possible to test the controller network using the test function in the software packages (*Communicate - Comms Test*). The PC sends out messages to the device and part of the contents of the message tells it how many messages have been sent.

The "D0000" is the number of these network test messages the device has received, and the "P0000" is the number of messages that the PC says have been sent.

If a *Comms Test* is carried out and these numbers aren't the same (or very close) then some messages have gone astray, possibly because of a bad network. In all cases it is advisable to leave the test running for several minutes so as to obtain a significant sample.

The "G0000" and "N0000" are network errors for the Global and Net comms networks respectively. These are not related to the *Comms Test* described above (although a failure on the there would also show up in the network errors list).

These are "receive" errors only since the device doesn't check its own transmissions. The device determines that a network message has failed by looking at the header and the message checksums, however if the message is so badly corrupted that it doesn't even begin correctly, it won't appear as a bad message rather the device will just ignore it until it sees the start of a proper message.

2-10-3-2 Commission – Network – Baud

From the *Network* display menu select *Baud* and press 

This screen displays the speed at which the two networks, Global and Net, communicate.

Net Comms (*NET*) – provides a means to configure or monitor the Maxim Series Digital Controller from a PC at a speed of 9600 or 57600 baud.



Figure 70 : Network Baud Rate Display

A local PC can be connected to the Net Comms via:-

- A MPI modem and printer interface unit
- a GENII Converter USB – USB/RS485 converter
- A GENII Converter NT – RS232/RS485 Converter (for legacy systems)
- A building Ethernet network, using a Maxim III "E" versions or a suitable RS485/Ethernet converter for other Maxim types.

A PC with a modem at a remote location can access this network through the telephone system via a modem connected to an MPI or GENII Converter NT on the Net Comms. Caution must be exercised if a PC and an MPI or more than one PC is directly connected to the Net Comms. Only one can be active at any time otherwise a conflict between them causes data corruption.

However, using Innotech IComm server software, many computers can simultaneously communicate with a single network. Many users can communicate with the IComm server, but only one device can connect to a RS485 network.

Global Comms (*GBL*) – provides a means for control data to be shared between the Digital Controllers and a GENII MPI at a data speed of 4800 or 38400 baud. There is no facility to connect a PC to the Global Points network through a Digital Controller or GENII MPI. If it is necessary to monitor the Global Points traffic, a GENII CONVERTER can be used to connect to the Global Points Comms cable and use the Genesis Global Points Monitor software to view the data.

Section 3 – Supervisor Mode

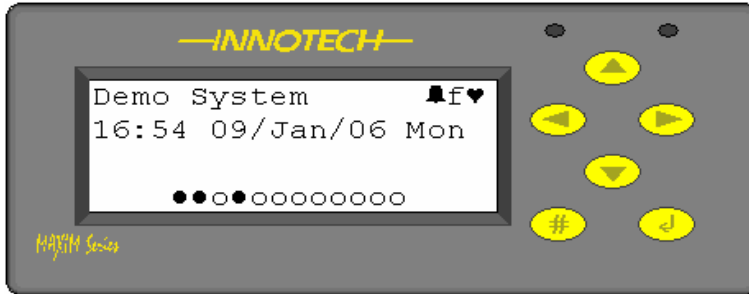



Figure 71 : Home Page Display

This is a protected access feature that allows the operator a greater level of adjustment than that of a normal user.

From the *Home Page*, right, press  and  together and hold until the display changes to the *Navigate* menu, Figure 69. This takes about 5-6 seconds.

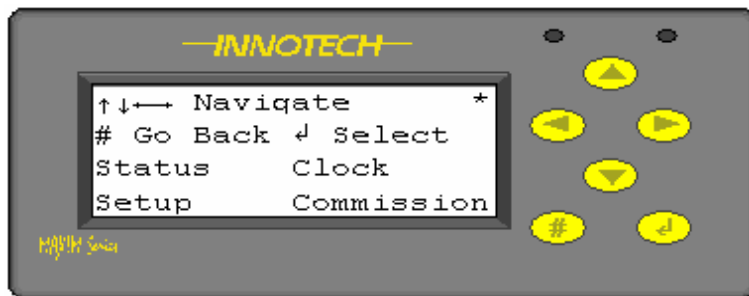

Figure 72 : Navigate Menu

A "*" is shown in the top right hand corner of the display when in *Supervisor Mode*.

If no buttons are pressed within any 5min period, the display will revert to the *Home Page* and logout from the *Supervisor Mode* automatically.

Only certain commands are changed within this mode and they are explained in the following pages.

3-1 Access Codes

When the controller is configured it is possible to prevent unauthorised access to any of the functions using Access Codes. These can only be set from within the MaxCon software and are downloaded to the controller during commissioning. The default setting in the MaxCon software is OFF, which means that access codes are ignored.

If access codes are enabled, there are two options:-

- *Only Supervisor code required* – If this option is selected access is allowed to the User level without any restrictions but to get to the Supervisor level the user has to enter the appropriate access code (Supervisor code).
- *Both User and Supervisor codes required* – If this option is selected access to both User and Supervisor level is allowed only after the appropriate access codes are entered (User and Supervisor code respectively).

Default access codes – When a new configuration is created, the MaxCon software fills in two default access codes – one giving access to a User level, and the other giving access to a Supervisor level.

Operating Instructions for Innotech Maxim Digital Controllers

- 0000 – User code
- 9999 – Supervisor code

If the codes are not known, upload the program using the MaxCon software and they can be obtained from the *Config\Access Codes* menu option. Also, remember that access codes are disabled by default.



Figure 73 : Access Codes (1)

To enter the access codes, press any key when the Home Page is displayed and the access code screen are displayed, right.



Use the  or  button to select the 4 digit code and as each number is highlighted press .



Figure 74 : Access Codes (2)



An asterisk will appear on the bottom line for each number entered. When all four numbers are entered correctly, press  again. If an incorrect code is entered, the display is show *Invalid Code* and time out after 5 seconds, returning to the Home Page.



Figure 75 : Access Codes (3)

If the correct code is entered the display is change to the Navigate Screen.

To change a code during entry highlight *Del*, and press  and the last number entered is removed. Press  again and the next number is removed and so on.

3-2 Status – Watches

It is possible to “lock” setpoints (See section 3-3.1 for further information) so that they cannot be adjusted in the normal user level. However, in Supervisor Mode any setpoint values defined as Watches can be adjusted. For further information on *Watches* refer to Section 2 of this manual.

3-3 Setup – General

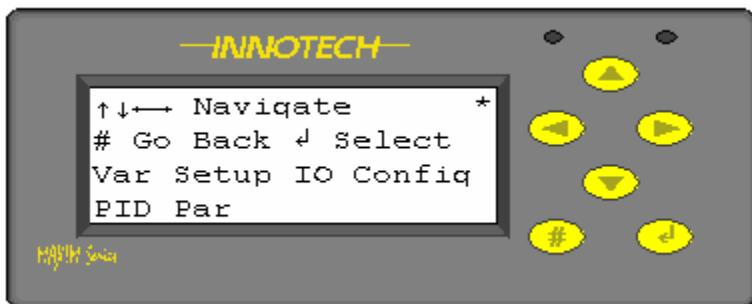

Figure 76 : Setup Menu (Supervisor Mode)

Press button to display the “Navigate” screen, press and to display the Setup menu. In this display *Var Setup* is flashing. Select this via or choose another option using , , , buttons and press .

3-3-1 Setup – VAR Setup (Locking Setpoints)



Figure 77 : VAR Setup

It is possible to “lock” setpoint Watches so they cannot be adjusted by casual users.

To do this, enter the *Var Setup* menu function and find the setpoint Watch you want to protect. A typical example is shown to the left.

- If *EDIT* = “Y”, it allows the user to change the value from the keypad from within the *Status/Watches* display at the normal user or default access level.
- If *EDIT* = “N”, the user cannot change the value unless they have access to *Supervisor Mode*.
- Press and the “Y” will flash. Use the , buttons to select the required characteristics (N = users cannot change the value, Y = allows users to change the value).
- Finally press to save the new setting.

✓ **Note:** this function only locks the adjustment from the keypad. The value can still be overridden via the *MaxMon* or *Magellan* software programs.

3-3-2 Setup – IO Config

This menu allows *Universal Inputs* or *Analogue / Digital Outputs* to be manually overridden by the operator.

Generally this is only done during the initial commissioning phase, but can be a useful tool during plant operation in the event of say, an outside air sensor failure causing a boiler shutdown.

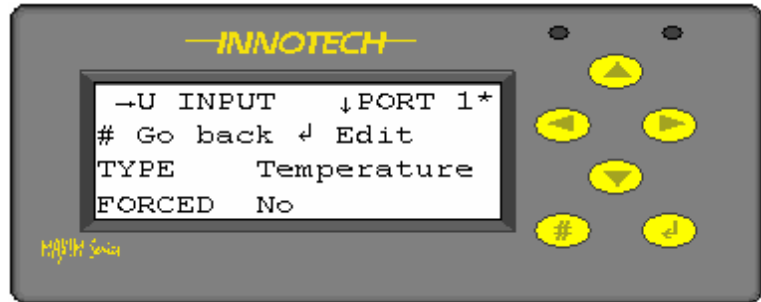





Figure 78 : IO Config Menu (1)

- Line 1 – defines input type and terminal number, above display shows Universal Input #1
- Line 2 – is a menu command and allows the user to return to the previous page
- Line 3 – defines the input type, in this case a measured value, Temperature
- Line 4 – defines whether the output has been *forced* (ie. manually overridden).

Using the  or  buttons, select the IO type. Paging to the right will display the Digital Inputs, then the Analogue Outputs. Select the correct type and use the  or  buttons to select the specific port required. A typical screen display is shown right.

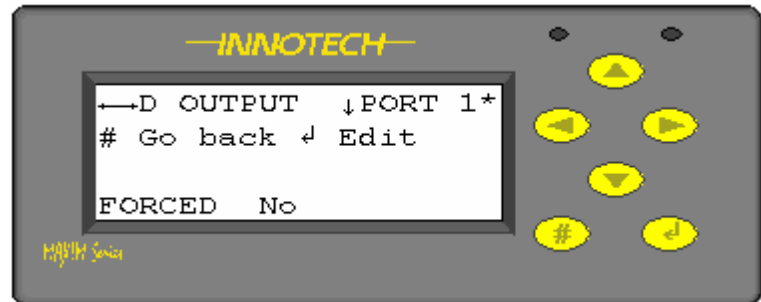







Figure 79 : IO Config Menu (2)

To *force* or manually override an input or output, press  and the displayed *FORCED* command will flash.

Press the  button, to change the display to Yes and the *FORCED* Value will then appear. Press  button to select this and the Forced Value will flash and using the  or  buttons, the override can be set to the value required.

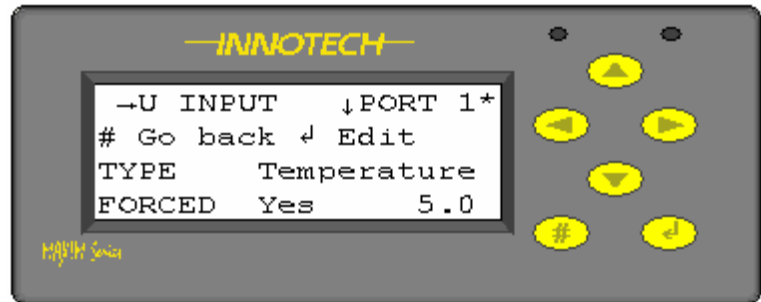

Figure 80 : IO Config Menu (3)

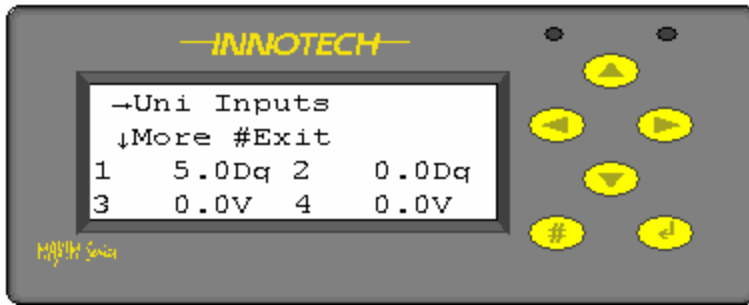

Figure 81 : IO Values Display

When finished, press to save or to abort the new setting.

When an input or output has been overridden, the Watch will display the forced value, but it will not show that it has been overridden. To see if any values have been manually forced, check the *IO Values* displays.

Where a manual override has been applied, the respective input or output will flash.

3-3-3 Setup – PID PAR

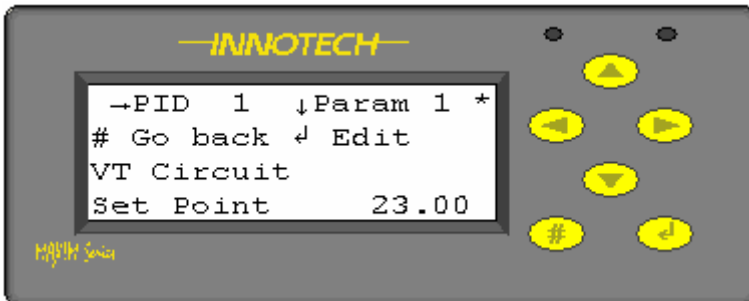

Figure 82 : PID PAR

This series of screen displays shows the user the internal block values for any PID control loops used within the software configuration of the controller. These can now be adjusted as required without having to connect a personal computer.

The PID Loop block is a twin output proportional plus integral and derivative control loop.

It is one of the primary control blocks used for maintaining constant temperature, humidity or controlled variable.

Line 1 – defines the PID block number, in the above case we are looking at PID Loop #1.

Line 2 – is a menu command and allows the user to return to the previous page or to edit the parameter currently being displayed.

Line 3 – defines the block name, in this case *VT Circuit*.







Line 4 – defines the internal setpoint, *23.00*. Press and change the parameter as required using the , buttons, and then press, to save the new value or to cancel.

Use the , buttons to display the other internal block values and settings, these are listed below:-

- *Setpoint* – This is the setpoint of the PID Loop to which the input to the block should finally settle, which is used only if the **SETPOINT** input to the block is not connected to a **User Variable**. This does not have to be connected, but doing so allows the setpoint to be modified (via an Editable Watch on a User Variable) during Maxim operation.
- *Dead Band* – This is the total range of the Dead Band for the PID Loop. This is the range of values (centred about the Setpoint) in which no Direct or Reverse acting control is used.

- *Alpha* – This is a smoothing constant (percentage) used in the integral and derivative calculations for the block. It is a representation of how fast the output value will change to meet the required value. An alpha of 100% will change immediately to the required value, whereas an alpha of 50% will only move half way toward the required value each time the block is processed. Note: If Alpha is set to 0% the block behaves the same as if it was set to 100% (otherwise the block output value would never change).
- *Direct P* (also *Direct I* and *Direct D*) – This group of fields provides for the setting of the Proportional Band range for the PID control loop as well as fine tuning of the derivative and integral constants for the calculation for the direct acting part of the PID Loop.
- *Reverse P* (also *Reverse I* and *Reverse D*) – This group of fields provides for the setting of the Proportional Band range for the PID control loop as well as fine tuning of the derivative and integral constants for the calculation for the reverse acting part of the PID Loop.

3-4 Commission

From the Home Page press the  button to display the "Navigate" screen. Use the , , ,  buttons to select the *Commission* function and then press  again.

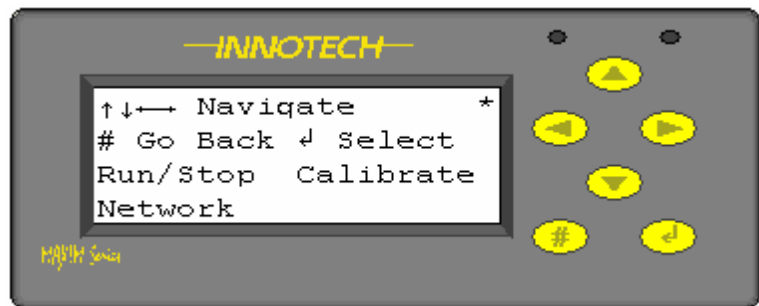

Figure 83 : Commission Display

3-4-1 Commission – Run/Stop

The *Run/Stop* function allows the controller processor to be stopped and started as required. When in the *Stopped* mode processing is suspended and the controller is effectively switched off (ie. analogue outputs would be *OV*, digital outputs would be *Off*).





Figure 84 : Run/Stop Display (1)

This function is extremely useful. It allows a controller to be pre-programmed prior to despatch but putting it into the *Stopped* mode allows it to be powered on site in a safe state. Once all the commissioning checks have been carried out and the user is satisfied all external devices have been correctly connected and configured, changing the state to *Running* then allows the application program to run.





Figure 85 : Run/Stop Display (2)

Line 1 – is a menu command and allows the user to return to the previous page  or  to *Stop* the processor.

Line 3 – is just a text display.

Line 4 – displays the current status of the processor and can be *Running* or *Stopped*.

Press  to toggle the processor between the states. When the required state has been selected, press  to return to the previous page.

3-4-2 Commission – Calibrate

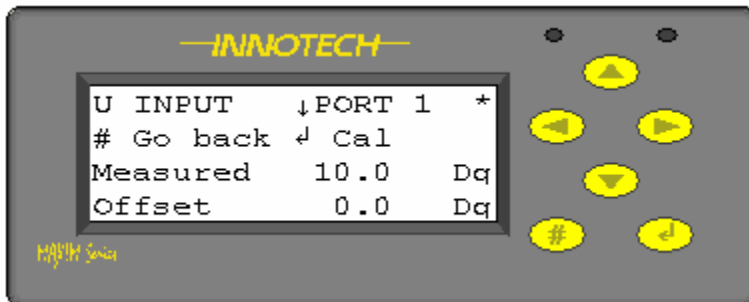

The *Calibrate* function allows the user to view the analogue inputs and see if the signal has been adjusted to take into account any variance in cable resistance or sensor calibration.





Press the ,  buttons to page through the inputs.

Figure 86 : Calibrate (1)

Line 1 – is a text value and shows the Input type, Universal Port no "1". There can be 6 analogue inputs on a Maxim I or II and up to 20 on a Maxim III.

Line 2 – Menu command. Allows user to return to previous page  or  *Calibrate* the input.

Line 3 – displays the *measured value* + the *Offset*

Line 4 – displays current *Offset* value. This is input by the Commissioning Engineer and is the actual measured temperature at the sensor *minus* the value being displayed at the controller.

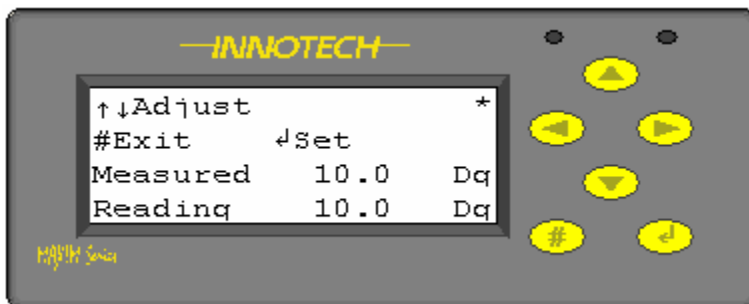

In the example shown, the controller is displaying a measured value of 10.0DegC. If say, the temperature was actually 11.0DegC as measured using a digital thermometer, a 1.0DegC *offset* can be entered to correct the displayed value. This can be + or -. Press  to enter the Calibration mode, above left.

Figure 87 : Calibrate (2)







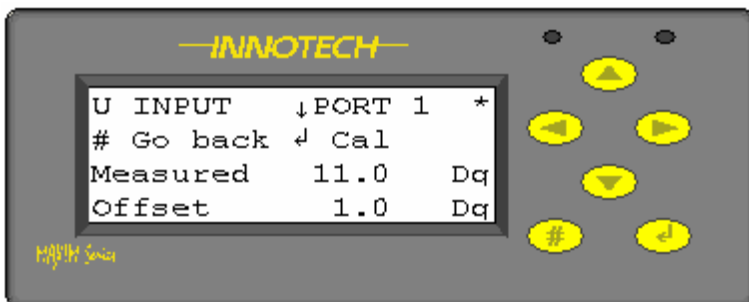

The Measured value is flashing at this point. Use the ,  buttons to change it to the actual measured temperature. Press  to save the revised value or  to exit to the previous screen. The controller will automatically calculate the sensor offset required and this is then displayed on Line 4.

Figure 88 : Calibrate (3)

Press  to return to the previous page and the display shows the adjusted values. The Measured value is shown in the respective watches.

Press  again to return to the *Commission* display.

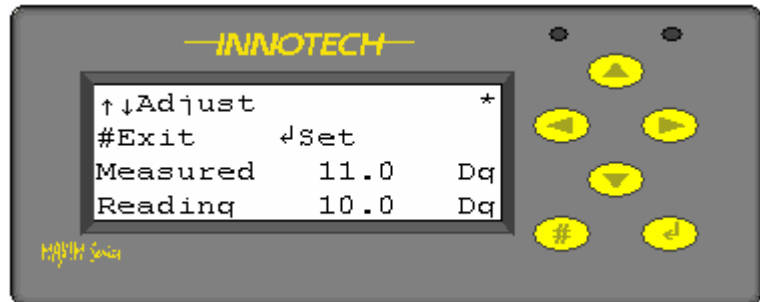



Figure 89 : Calibrate (4)

3-4-3 Commission – Network

From the *Commission* page select *Network* and press the  button to display the screen below. The information displayed is read only.

3-4-3-1 Commission – Network – Status

From the *Network* display menu select *Status* and press . It is possible to test the controller network using the test function in the software packages (*Communicate – Comms Test*). The PC sends out messages to the device and part of the contents of the message tells it how many messages have been sent.

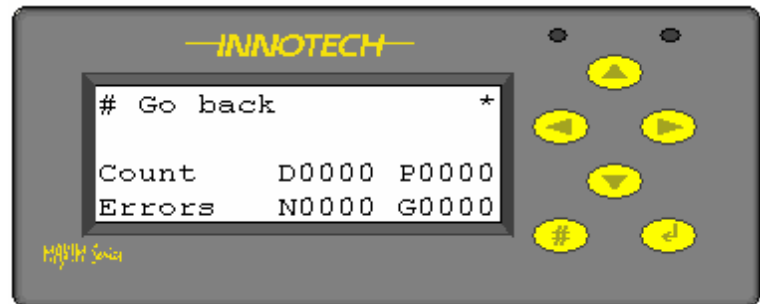

Figure 90 : Network Status

The “D0000” is the number of these network test messages the device has received, and the “P0000” is the number of messages that the PC says have been sent.

If a *Comms Test* is carried out and these numbers aren't the same (or very close) then some messages have gone astray, possibly because of a bad network. In all cases it is advisable to leave the test running for several minutes so as to obtain a significant sample.

The “G0000” and “N0000” are network errors for the Global and Net Comms networks respectively. These are not related to the *Comms Test* described above (although a failure on the there would also show up in the network errors list).

These are “receive” errors only since the device does not check its own transmissions. The device determines that a network message has failed by looking at the header and the message checksums, however if the message is so badly corrupted that it does not begin correctly, it will not appear as a bad message, rather the device will just ignore it until it sees the start of a proper message.

3-4-3-2 Commission – Network – Baud Rate

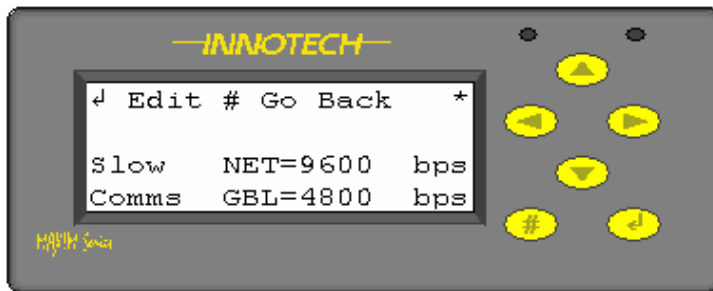

Figure 91 : Network Rate (1)

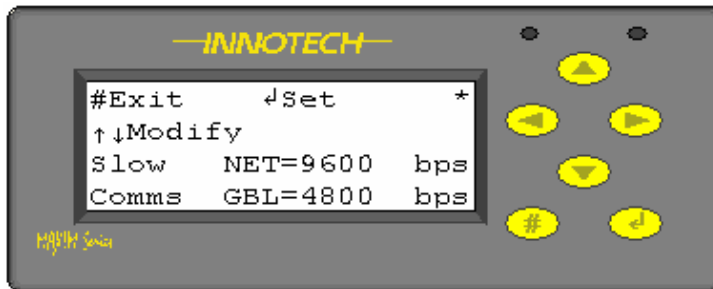

Figure 92 : Network Rate (2)

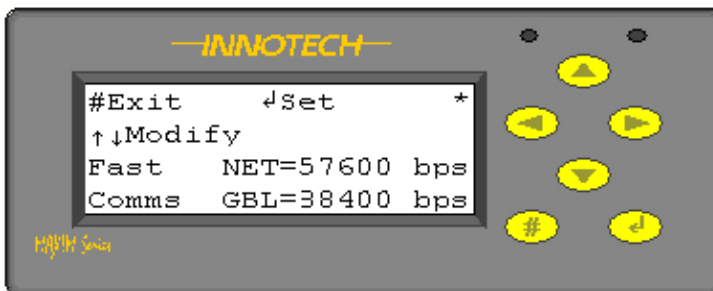







Figure 93 : Network Rate (3)

From the *Network* display menu select *Baud* and press 

This screen displays the speed at which the two networks, Global and Net will communicate with other controllers

Note: V5.1 firmware or below only allows the network to run at the lower Baud rates

To change the selected speed, press , the Slow Comms or Fast Comms will start to flash. Press the ,  buttons and select the required speed and then press  to save the new value or  to exit to the previous screen.

Firmware v6.0 or above allows higher speeds to be selected. Where controllers with new firmware are fitted to legacy systems, the Slow Comms speeds will need to be selected.

On systems where only the new devices are used the Fast Comms speeds can be used.

Net Comms (*NET*) – provides a means to configure or monitor the Maxim Digital Controller from a PC at a speed of 9600 or 57600 baud.

A local PC can be connected to the Net Comms via an MPI or via a GENII Converter USB (USB/RS485 converter) or for legacy systems a GENII Converter NT (RS232/RS485 Converter) can be used.

A PC with a modem at a remote location can access this network through the telephone system via a modem connected to an MPI or GENII Converter NT on the Net Comms. Caution must be exercised if a PC and an MPI or more than one PC is directly connected to the Net Comms. Only one can be active at any time otherwise a conflict between them causes data corruption.

Global Comms (*GBL*) - provides a means for control data to be shared between the Digital Controllers and a GENII MPI at a data speed of 4800 or 38400 baud. There is no facility to connect a PC to the Global Points network through a Digital Controller or GENII MPI. If it is necessary to monitor the Global Points traffic, a GENII CONVERTER can be used to connect to the Global Points Comms cable and use the Genesis Global Points Monitor software to view the data.

Section 4 – Glossary of Terms

- ACCESS CODE** : A password code that the operator must enter into the Digital Controller, prior to operation, in order to have access to plant or system information. The Access Code assigned to an operator determines what specific information that operator is allowed to access. Access Codes are four-digit numeric codes such as 4567, 3941 or 1111 – zeroes are not used.
- AI** : Analogue Input, refers to the physical input into a control device.
- AISC** : Analogue Input Signal Conditioner – a small interchangeable circuit board used on the Genesis control range analog inputs to provide a high degree of flexibility for the input signals used.
- AO** : Analogue Output, refers to the physical input into a control device.
- BLOCKS** : A functional processing unit inside the Maxim which may have inputs connected to it and may generate outputs.
- BUILDING MANAGEMENT SYSTEM** : Building Management System describes the technology of controls associated with space heating, air conditioning, hot water service and lighting in buildings.

The technology area of building management systems & controls includes a variety of systems, over a wide range of complexity, designed for the control, monitoring and optimisation of various functions and services provided in a building, including heating and cooling, ventilation, lighting and often the management of electric appliances.
- CURSOR** : A marker on a display screen that identifies the part of the display selected for observation or for entry/change of data. A cursor can identify a complete line item in a list of items (called a menu) or it can identify a part of a numeric value that can be changed (edited) by the operator.
- DDC** : Direct Digital Controller – another commonly used name for the Innotech Genesis II Digital Controller.
- DDE** : Dynamic Data Exchange (DDE) protocol. The DDE protocol is a set of messages and guidelines. It sends messages between applications that share data and uses shared memory to exchange data between applications. Applications can use the DDE protocol for one-time data transfers and for continuous exchanges in which applications send updates to one another as new data becomes available.

This is the interface between the Innotech Genesis and Maxim Controllers and the various Innotech software packages. Although still available it has generally been superseded by the Innotech IComm server application.
- DEFAULT** : When the operator is expected to make a choice during an operation but does not do so, the software then makes the choice “by default”. For example; if, during the unit's configuration process, the user does not assign specific access codes for the User and the System Pages, but still selects Access codes, the system automatically establishes the default access codes: 1111 and 9999 respectively.
- DI** : Digital Input, refers to the physical input into a control device.
- DO** : Digital Output, refers to the physical input into a control device.

Operating Instructions for Innotech Maxim Digital Controllers

- EDIT** : To make changes to text or numerals on a display screen. Certain process values, as permitted by the system configuration, can be edited using front panel controls.
- EEPROM** : Electrical Erasable Programmable Read Only memory chip. A type of ROM that can be erased electronically and reprogrammed in-circuit (or with a device programmer). From the programmer's perspective, EEPROM is very similar to flash memory. The biggest difference is that the bytes (words) of an EEPROM can be erased individually.
- FLASH WATCH** : The information presented on the third and fourth lines line of a Home Page when the Digital Controller is configured for flash watches. The flash watch allows the operator to monitor specific data rapidly without having to select and scroll through a watch page.
- Flash watch data is displayed cyclically at a rate of twelve lines per minute. Each flash watch lasts for five seconds and is then automatically replaced by the next flash watch, and so on. After the last flash watch in a group (see FLASH PAGE) is displayed, the cycle repeats itself.
- FLASH PAGE** : An inclusive name given to the group of flash watches. There can be up to 16 flash watches in a flash page. "Flash Page" is a fictitious term in that the operator never sees anything resembling a page. The operator only sees one flash watch at a time.
- HMI** : Human Machine Interface, specifically in reference to the Maxim Controllers, Maxim Miniport or Genesis Viewport network keypads.
- HOME PAGE** : The name given to the presentation the operator sees on the screen when a watch page or system page is not displayed. The home page is the first presentation the operator sees:-
- Before entering the access code
 - After entering the access code but before accessing a watch page or system page
 - Between watch/system pages
- HV** : Heat Valve – applies to the application of solid state relays used to control electric heater batteries. In this particular application, PWM outputs would "fire" the solid state relays and control the amount of power to the heater battery coils, thus controlling the heat output.
- HVAC** : Heating, Ventilation and Air Conditioning.
- IC** : Integrated Circuit – is the formal name for a die, or chip. Its name resulted from the integration of previously separate transistors, resistors and capacitors, all on a single chip.
- IO** : Input/Output, refers to the AI, AO, DI and DO physical input or output.
- LOG-ON** : To enter an access code prior to operating the Digital Controller – thus the operator's identity is "logged" in the unit's software.
- MENU** : A list of functions presented to the operator on the screen. The operator can choose any of the functions to be accessed for further action.

- MOTHERBOARD** : The main circuit board assembly in a computer. Other, smaller, circuit boards usually plug into connectors on the motherboard. Printed circuit wiring traces on the motherboard provide an interconnection bus structure between the plug-in circuit boards and the motherboard. Other components, such as microprocessor chips, light emitting diodes, etc. are often mounted on the motherboard.
- PLC** : Programmable Logic Controller.
- PI** : Pulse Input.
- PROPORTIONAL BAND** : Otherwise known as PB. This is the deviation of the measured value from setpoint over which the output reaches 100%.
- PROMPT** : A visual clue presented to the operator suggesting the next operation to be performed by the operator.
- PWM** : Pulse Width Modulation – control method where the output is fully on or fully off. The voltage is supplied to the load by means of a repeating series of on and off pulses. The *on-time* is the time during which the DC supply is applied to the load, and the *off-time* is the period during which the supply is switched off.
- READOUT** : A term commonly used in computer work; it means any type of alphanumeric message presented on a display screen. PRINTOUT is the equivalent for a printed copy.
- ROM** : Read-only Memory – a memory device that normally cannot be written into; data can only be read out of the ROM. In the Digital Controller, the operating program is written into (stored in) the ROM when the unit is configured by the Innotech MaxCon configuration software. The program remains in the ROM unchanged (except for changes to setpoint values) until the unit is reconfigured. The combination of ROM (hardware) and operating program (software) is often referred to as FIRMWARE.
- SCROLL** : The up or down movement of lines of data on the display screen to place individual lines in a location where they can be easily viewed. It is the equivalent of moving a paper scroll up or down before the eyes to view specific parts of the information on the page. In addition to up/down movement, scrolling can also be right/left.
- SELV** : Safe Extra Low Voltage – A secondary circuit which is so designed and protected that, under normal and single fault conditions, its voltages do not exceed a safe value.

The secondary circuit has no direct connection to the primary power and derives its power from a transformer, converter or equivalent isolation device, or from a battery.
- SSR** : Solid State Relay – A solid-state relay is an ON-OFF control device in which the load current is conducted by one or more semiconductors (eg. a power transistor, an SCR or a TRIAC). (The SCR and TRIAC are often called “thyristors,” a term derived by combining thyatron and transistor, since thyristors are triggered semiconductor switches).
- UI** : Universal Input, a physical input that can be configured in a number of different ways, generally as an AI or DI.

Operating Instructions for Innotech Maxim Digital Controllers

- UO** : Universal Output, a physical output that can be configured in a number of different ways, generally as an AO or DO. In the latter case this is normally achieved by switching the 0-10v from low (0v) to high (10v) and using a voltage sensitive relay (DC) to provide the actual relay contact.
- USER CODE** : Another name for Access Code.

INNOTECH

Innovative technology

Australian Owned, Designed & Manufactured
by Mass Electronics Brisbane

Ph: + 61 7 3841 1388 **Fax:** + 61 7 3841 1644

www.innotech.com.au Email: sales@innotech.com.au

Your Distributor