

MODELS:
MT02: MAXTime 24 V

TYPE: 24 V 4 Channel Timeswitch
With Optimum Start

Overview

The Innotech *MT02* is a 24 V 4 Channel programmable 365 Day timeswitch with optimum start capabilities. Its applications include Air Conditioner Plant scheduling and usage optimising, Domestic and Commercial Lighting, Security and virtually any application that requires events to occur at a scheduled time.

Features

- 4 Independently programmable Relay channels
- After Hours capability on all channels
- 4 line, 80 character Liquid Crystal Display
- Optimum Start on All Channels with Thermistor inputs
- 32 On/Off Weekly Events per Channel
- 20 On/Off Yearly Events per Channel
- 20 On/Off Master Yearly Events (All Channels)
- User Programmable After Hours Timer
- Current Time and Date (Battery Backed)
- After Hours Usage Log (Battery Backed)
- Automatic Daylight Savings Adjustment
- All Configuration and Schedule Data is stored to non volatile memory
- Calibration function for Thermistor inputs
- Operates on 24 V AC
- DIN Rail mountable

Approvals

The Innotech *MT02* conforms to:

- Electromagnetic emission and immunity requirements for information technology equipment, EN55011:1991 (CISPR11) and EN50082-1:1992 for CE Marking and C-Tick labelling.

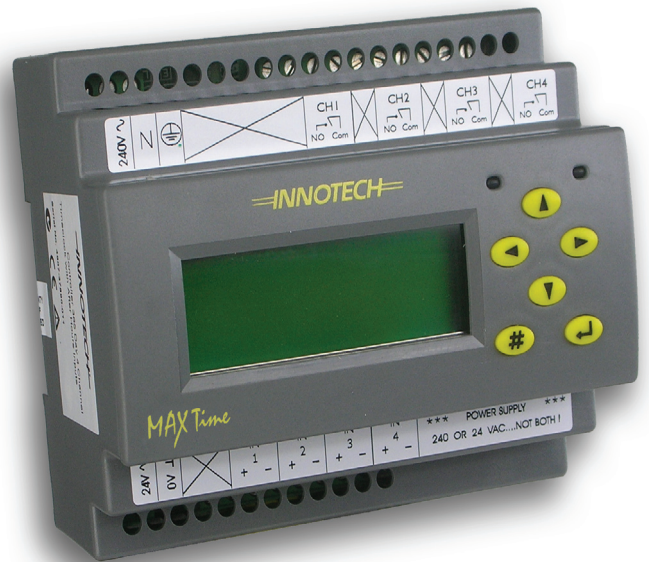

Applications

The *MT02* can be used in a variety of situations that require automatic on/off scheduling. Its optimum start functionality make it particularly useful for Air Conditioning applications.

- Air Conditioning scheduling
- Optimum Start Function reduces power consumption
- Automatic Security Light activation
- Timed control of Plant and Equipment
- Internal After Hours Timers

Specifications

Power Supply

- 24 V AC \pm 10% @ 50/60Hz

Sensor Wiring

1. DO NOT connect 24 V or 240 V AC to “IN+ and IN-” terminals.
2. Screened cable should be used between the sensor and the MT02. The screen is terminated to the IN-.
3. The temperature sensor is connected between the IN+ and IN- terminals.

Temperature Ratings

- Storage: 0 to 50°C non-condensing.
- Operating: 0 to 40°C non-condensing.

Enclosure & Mounting

The Innotech *MAXTime 24 V* is housed in a rectangular case suitable for DIN Rail mounting. The housing is moulded from flame retardant plastics recognised by UL as UL 94-V0.

Colour: Grey

Dimensions (max): 89mm (l) x 107mm (w) x 69mm (d)

Installation

- The *MAXTime 24 V* should be mounted on DIN rail in cabinets approved for switchgear or industrial control equipment. It should be mounted in a dry and clean location, free of excess vibration. Maximum terminal cable entry is 1.5mm² wire.
- Wire in accordance with Innotech connection diagrams and local bylaws or refer to your local distributor.
- Voltage: 24 V AC* \pm 10% 50/60Hz (across terminals 24 V~ & 0 V \perp).
Power Consumption: 7 VA Max.
*When powered by 24 V AC, the operating voltage must meet the requirements of safety extra low voltage (SELV) to EN 60730. The Transformer used must be a Class 2 safety transformer that has the energy and voltage limiting characteristics as described in the National Electrical Code, ANSI/NFPA70. It must also be sized and fused in compliance with local safety regulations.

Battery

Contains a Lithium Battery, dispose of properly

- Type CR-2032 Lithium Battery
- Nominal voltage 3 Volts
- Shelf life - 5 Years dependant on ambient temperature

Caution - Risk of explosion if battery is replaced by an incorrect type

Inputs

- 4 x 10K NTC Thermistor / Dry Contact Digital Inputs
Thermistor Input Range: 0°C to 50°C
- NOTE: The Controller can be configured for use in any one of the 4 following methods:
 1. No optimum start sensor and no after hours push button
 2. An optimum start sensor and no after hours push button
 3. No optimum start sensor and an after hours push button
 4. An optimum start sensor and an after hours push button

Outputs

- 4 x 2Amp @ 24 V AC Relays, Normally Open supplied by a Class 2 Transformer.

Interface

The interface of the *MAXTime 24 V* comprises of a 4 line, 80 character Liquid Crystal Display (LCD) with Directional Cursor Keys, Escape (#) and Enter keys. A menu system with on-screen user instructions ensures ease-of-use.

The Default screen of the display shows the current time and status of all relay channels. Pressing Enter on the keypad will take the user to the menu system where schedule and configuration changes can be made. The display always returns to the default screen if no keys are pressed within two minutes.

The Schedule Menu allows the user to Add, Edit or Delete Weekly and Yearly Schedules. Weekly Schedules require a Start and Stop time in Hours, Minutes and Day of Week. Yearly Schedules require a Date, Month and Year. The Yearly schedule will override all weekly schedules from 0:00 of the Start Date to 24:00 of the Stop Date. i.e. A Weekly Schedule for Monday 9:00 to Monday 17:00 on Relay Channel 1 will activate that relay every Monday between 9:00 and 17:00. If however, a yearly exception schedule set to Start on 2nd September 2002 and Stop on the Same day, will override the Weekly Schedule to off, since 2nd September 2002 is a Monday.

In addition to the Individual Yearly Schedules for each channel, Schedules entered into the Master Yearly Schedule will override all weekly schedules on all channels. This is a convenient way to add holiday periods to all channels instantly.

The After Hours features can also be accessed from the Schedules menu. This screen will display the Time remaining for any channels where the after hours function has been activated. The Total accumulated hours of After hours usage for each channel (battery backed log) and the After Hours delay can be adjusted by the user in 15 minute intervals from 15mins to 8 hours.

Note that the After hours timer cannot be activated if that channel is currently activated from a schedule. Also, if the After hours timer is triggered prior to the start of a scheduled event, the After hours log will accumulate only for the time used outside the schedule.

To reset the accumulated After hours log for a particular channel, press and hold the ENTER Key for 5 seconds while the accumulated time is displayed. The After hours log for that channel will then be reset back to zero.

The Clock Menu allows Setting of the System time and the Daylight Saving Parameters. When the System time reaches the calculated Daylight Saving Start Date, the System time will advance by one hour. When the System time reaches calculated Daylight Saving Stop Date, the System time will retard by one hour. Both the System time and Daylight Saving Parameters are battery backed and will be retained in the absence of a supply voltage.

The Calibrate menu can be used to view the measured temperature when a thermistor is connected to any of the input terminals. The measured value can then be adjusted by an offset value which will change the measured temperature as seen by the optimum start algorithm.

The Optimum start (OptStart) menu is used to configure parameters and enable/disable the optimum start control algorithm. When enabled, the optimum start will affect all schedules for that channel. The optimum start parameters are:

1. Setpoint
Desired temperature to be achieved at occupied time (scheduled start time).
2. Alpha
A smoothing filter applied to changes to the optimum start output.
3. Deadband
This defines the total temperature deadband.
4. Heat Value
This is a parameter of the building the optimum start is used in. The optimum start uses this value to estimate the time required to start heating before scheduled time. Each time the optimum start runs, it will recalculate this value and apply the alpha value from parameter 2. This parameter is in °C/Hour since it is the number of degrees celcius that the air conditioning plant can heat the building within one hour.
5. Cool Value
As per Initial Heat except applies to cooling.
6. Maximum Prestart.
In minutes. This is the maximum number of minutes the optimum start is allowed to start before the scheduled time.

FCC Class A Notice

This device complies with Part 15 of the FCC Rules. Operation is subject to the following two conditions:

1. This device may not cause harmful interference.
2. This device must accept any interference received, including interference that may cause undesired operation.

Note – This equipment has been tested and found to comply with the limits for a Class A digital device, pursuant to Part 15 of the FCC Rules. These limits are designed to provide reasonable protection against harmful interference when the equipment is operated in a commercial environment. This equipment generates, uses and can radiate radio frequency energy and, if not installed and used in accordance with the instruction manual, may cause harmful interference to radio communications.

Operation of this equipment in a residential area is likely to cause harmful interference in which case the user will be required to correct the interference at his own expense.

Modifications to this device, may void the authority granted to the user by the FCC to operate this equipment.

Connection Diagram

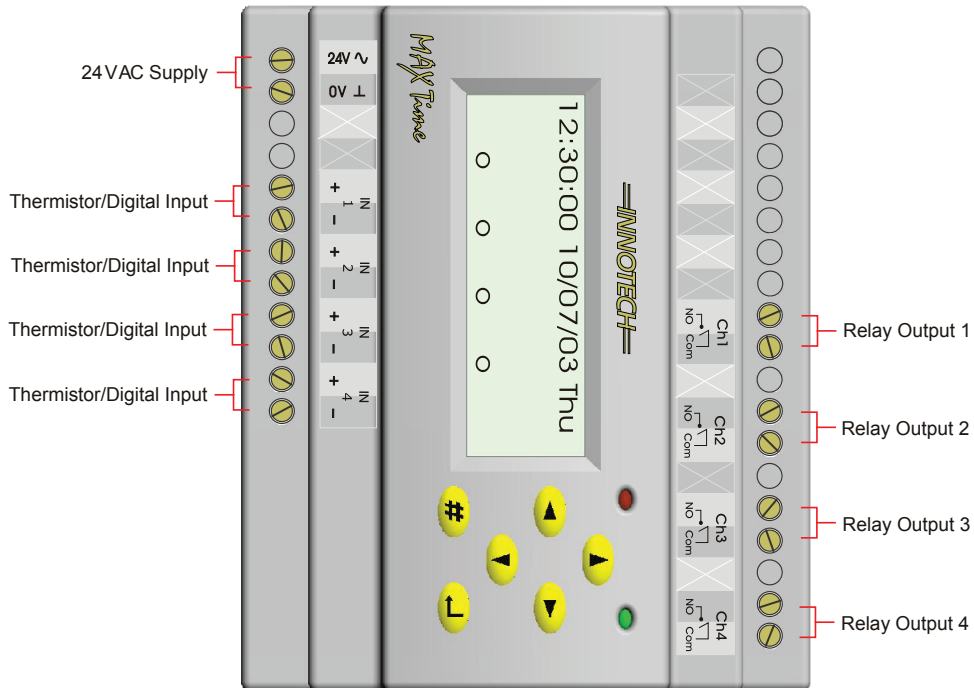

INPUT WIRING

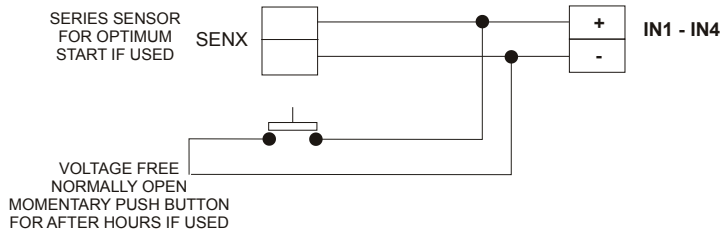

INNOTECH®
Innovative technology

Australian Owned, Designed & Manufactured
 by Mass Electronics Brisbane

Phone: + 61 7 3841 1388 Fax: + 61 7 3841 1644
 Email: sales@innotech.com.au www.innotech.com.au

YOUR DISTRIBUTOR