

MODEL:
ICS01: ON/OFF, Set Point
ICS02: ON/OFF, Set Point and 3 Speed Fan

TYPE: ICS0x
Innotech Control Station

Overview

The ICS series Control Stations form part of the Maxim & Genesis Direct Digital Controller range and provide a simple unitary Human Machine Interface (HMI). The HMI offers on/off, setpoint and fan speed control. The HMI is powered by 24V AC and connects directly to the Globals Comms network.

Each ICS can communicate with a designated controller on the network. The ICS units are configured via the Keypad, are compatible with most existing Innotech digital products and are capable of operating at both fast or slow comms.

The interface to the controller is via global Transmit and receive blocks, the configuration simply uses the ICS address to form part of the unique point name.

Features

- One numerical value input
- One numerical value output
- One momentary push button digital input
- One LED indication digital output
- One fan speed input (ICS02 only)
- Housed in a switchplate that mounts in standard electrical wall plates
- Isolated RS485 interconnection between Innotech Controllers
- Adjustable user input range
- Adjustable decimal place
- Configurable power on settings.

Application Notes

The *Innotech Control Station* extends the capabilities of Innotech controllers by providing a numerical value output, numerical value input, push button digital input and a single LED display output for distributed control via RS-485. The *Innotech Control Station* provides a visual display of a control value and a means to set a parameter. It is not intended for use on a large controller network as this affects the operation.

Models

Feature	ICS01	ICS02
On/Off	Yes	Yes
Temp. Display	Yes	Yes
Setpoint Adjust	Yes	Yes
Run Status	Yes	Yes
Fan Speed	No	Yes



Installation

- Strictly follow the guidelines when installing the Comms wiring as outlined in the Genesis System Comms Wiring Recommendations.
- Mount the *Innotech Control Station* in a dry and clean location free of excess vibration.

Wiring

- **DO NOT** connect 240V AC to any terminals.
- The cable used for RS485 Comms must be shielded single twisted pair, 120 ohms character impedance, 36 to 45pF per metre capacitance between conductors.
- The Comms cable must be organised as a bus topology. That is, starting at one end, devices are connected to it until the other end of the cable is reached. No "stubs" are allowed. To connect a device to the cable, a cut is made in the cable at the point where the device is to be situated along it. Then, the two new ends of the cable are wired into the device. The shields from the two new ends are then terminated into the terminals marked SHLD1. Refer to the Genesis Network Installation Instructions and DS99.04 Cabling Manual for more information.

Approvals

The *Innotech Control Station* conforms to the requirements of EN61326:1998 for CE-Marking as well as to Australian requirements for C-Tick Labelling.

Specifications

Power Supply

- Voltage: 24 volts AC $\pm 10\%$ @ 50/60Hz.
- Power Consumption: 3VA max.

Inputs

- Push buttons for adjusting control values.
- Push button for momentary input of “digital function”.

Outputs

- No physical outputs.
- Display of Temperature and Setpoint.

Terminal Identification

- | | | |
|---|---|-----------------|
| 1 | = | 24 V AC Supply. |
| 2 | = | 0 V AC Supply. |
| 3 | = | Earth. |

Note: Terminal 3 is for the protection of the Comms circuitry and must be connected to a good electrical bonded Earth.

COMMS Connection

- | | | |
|----|---|-----------------------------------|
| S1 | = | Shield from incoming Comms Cable. |
| + | = | RS485 (+) signal. |
| - | = | RS485 (-) signal. |
| S2 | = | Shield from outgoing Comms Cable. |
- Do not connect. Only used on REM Networks

Temperature Ratings

- Storage 0 to 50°C non-condensing.
- Operating 0 to 40°C non-condensing.

Enclosure

The *Innotech Control Stations* are housed in switchplate that mounts in standard electrical wall plates.
 Colour: White
 Wall mounted.

Innotech Controller Configuration

The interface to the Innotech Control Station is with the use of Global Blocks in the configs executed on Innotech Controllers (genesis and Maxim families). The Innotech Control Stations have the following pre-defined Global Blocks:

- CS:xxx AI Set Point Adjust
- CS:xxx AO Temperature Display
- CS:xxx DI On/Off
- CS:xxx DO Run Status
- CS:xxx FS (ICS02 Only) Fan Speed (0, 1, 2, 3)

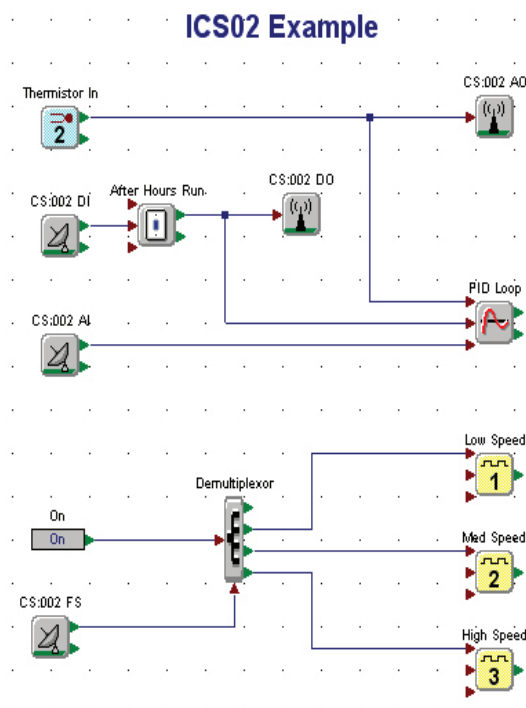

Where xxx represents the three digit address. (ie. Address 10 is 010, Address 5 is 005)

To access the points on the Innotech Control Station, Global Blocks with names corresponding to the above names need to be placed in the config. The figure below provides an example for an ICS02 at network address 2:



Program Functions Of The Innotech Control Station

To Enter Programming Mode:

To enter Programming mode depress and hold the  and  buttons for 5 seconds. The display will become blank indicating that you are in the Programming Mode. Release both keys and the display will show parameter 0.

Whilst in the programming mode the following buttons are active:



Change to the next parameter.



Increase the current parameters value.



Decrease the current parameters value.

Parameter 0 - Global Address

The display will show the current GLOBAL Address of the device.

- The range of address is 2 to 127. The default address is 2.

Parameter 1 - Maximum Input Value

The display will show the Maximum Input Value to which the module's input can be set.

- The range of Maximum Input Value is 0.0 to 99.9.
- The factory default setting is 30.0

Parameter 2 - Minimum Input Value

The display will show the Minimum Input Value to which the module's input can be set.

- The range of Minimum Input Value is 0.0 to 99.9.
- The factory default setting is 15.

Parameter 3 - Decimal Places

The display will show the number of decimal places which will be displayed for both the input and output values.



- The range of Decimal Places is 0 to 2.
- The factory default setting is 1

Parameter 4 - Baud Rate

The display will show an indication of the communications Baud Rate:

- 0 = 4800 Baud
- 1 = 38400 Baud
- The factory default setting is 38400 Baud.

To Exit Programming Mode:



To exit the Programming Mode depress the  and  buttons and the new setting will be saved.

NB. IF PARAMETER 4 IS CHANGED, POWER TO THE ICS0X MUST BE RECYCLED, AFTER EXITING PROGRAMMING MODE.

Start Up Default Settings

The *Innotech Control Station* Module can be set to start with default settings for Set Point, Run Status and Fan Speed (ICS02 only).

To set the start up default settings adjust the *Innotech Control Station* to the desired Set Point, Run Status and Fan Speed (ICS02

only) and then press and hold the  and  buttons for 5 seconds.

The display will become blank indicating that the new default start up settings have been saved.



Operating Functions Of The Innotech Control Station

Numerical Output:



The *Innotech Control Station* will display a 4-digit value with up to 3 decimal places.

Numerical Input:

The *Innotech Control Station* will provide a 4-digit value with up to 3 decimal places to Innotech controllers on the global network.

The value can be modified by pressing the  button to increment by the least significant digit or the  button to decrement by the least significant digit.



Digital Input Value:



The  button on the *Innotech Control Station* provides a digital input value to the Innotech Controllers. This operates as a standard momentary switch, i.e. Pressing the  button produces a short period ON value to the controller.

Digital Output LED:

The *Innotech Control Station* displays a digital state via the system LED during normal operation. This LED, however, cannot be overridden whilst the Digital Input Value is in a transitional state.

Fan Speed Button (ICS02 Only):

The  button provides means of setting a fan speed. Pressing the  button cycles between low/medium/high fan speeds.

This is indicated on the LEDS above the  button. The  button and LEDS are disabled whilst the Control Station is off (ie. there is no ventilation only mode).

Global Comms Wiring

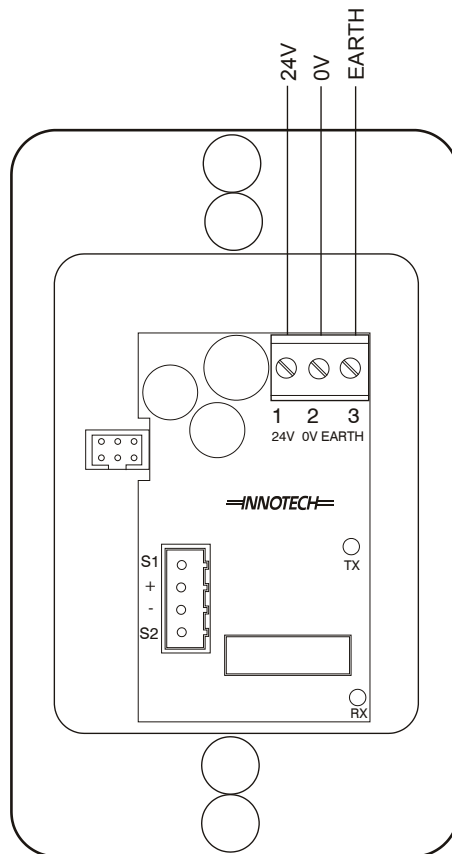
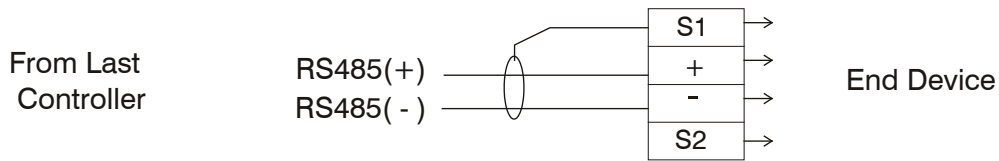
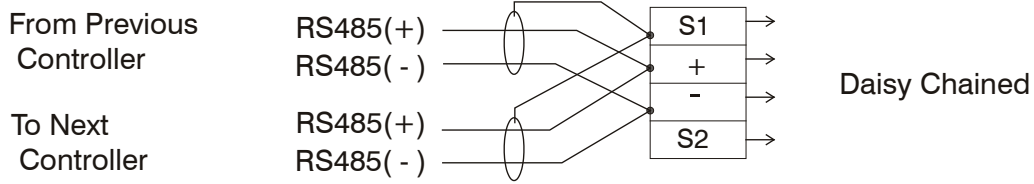

INNOTECH®

Innovative technology

Australian Owned, Designed & Manufactured
 by Mass Electronics Brisbane

Phone: + 61 7 3841 1388 Fax: + 61 7 3841 1644
 Email: sales@innotech.com.au www.innotech.com.au

YOUR DISTRIBUTOR