

GENII CS REM

GENII CS REM Control Station Module

Overview

The Innotech *GENII CS REM* Control Station Module is an expansion device for the GENESIS range of Digital Controllers.

The module is powered by 24VAC and provides a limited User Interface to the GENESIS Controller. There are no physical connections between field equipment and the GENII CS REM, all input/output values are edited and viewed on the wall unit.

The *GENII CS REM* may be located remotely from the GENESIS Digital Controller providing a distributed User Interface for the system.

The *GENII CS REM* is configured via the wallplate and programmed via the GEN2Config Software.

The *GENII CS REM* communicates with the Genesis controller via the REM Comms port. The remote link uses RS-485 at a baud rate of 38400. For pre-Version 5 controllers, a Gen II RMI Remote Module Interface is required. Please refer to DS15.01 for further information.



Features

- One single decimal place numerical value input
- One single decimal place numerical output
- One toggle digital input and one LED digital display output.
- Housed in a switchplate that mounts in standard electrical wall plates.
- RS485 interconnection between REM Modules.
- 24V AC operation.
- Wiring Diagrams for modules generated by GEN2Config Software.
- Adjustable user input range.
- Configurable power on settings.
- Display Auto Dim when lights out.

Application Notes

A GENESIS Controller must have version 4 firmware installed to support REM Modules. Version 4.0 or higher Config Software must be used to configure a GENESIS Controller that has REM Modules connected to it.

Application Notes cont.

One GENESIS Controller can have up to 15 *GENII CS REM* Modules* connected to it via the REM comms bus.

For detailed connection information to the pre version 5 GENESIS Digital Controller Family, please refer to DS 99.03

Applications

- Expands GENESIS Controller capabilities by providing a numeric output display, numerical value input, a single toggle digital input switch and single LED display output for distributed control via RS485. The *GENII CS REM* Module provides a visual display of a control value and a means to set a parameter.

Approvals

The *GENII CS REM* conforms to:

- EN 55011 Class B Group 1 & EN 50082-1 for CE Marking
- AS/NZS 2064:1997 for C-Tick Labelling.
- FCC Title 47 CFR, Part 15 Class A for FCC Marking
- UL listed to UL916, File Number E242628

Specifications

Power Supply

- Voltage: 24 volts AC $\pm 10\%$ @ 50/60Hz.
- Power Consumption: 3VA max.

The operating voltage must meet the requirements of Safety Extra Low Voltage (SELV) to EN60730. The transformer used must be a **Class 2 safety transformer** that has the energy and voltage limiting characteristics as described in the National Electrical Code, ANSI/NFPA70. It must also be sized and fused in compliance with local safety regulations.

Inputs

- Push buttons for adjusting control values.
- Push button for toggling of "digital function".
- Push button for timer initiation.

Outputs

- No physical outputs.
- Display of Temperature and Setpoint.

Terminal Identification

- | | | |
|---|---|----------------|
| 1 | = | 24V AC Supply. |
| 2 | = | 0V AC Supply. |
| 3 | = | Earth. |

NOTE - TERMINAL 3 is for the protection of the Comms circuitry and must be connected to a good electrical bonded Earth.

COMMS Connection

- | | | |
|--------|---|-----------------------------------|
| SHLD 1 | = | Shield from incoming Comms Cable. |
| + | = | RS 485 (+) signal. |
| - | = | RS 485 (-) signal. |
| SHLD 2 | = | Shield from outgoing Comms Cable. |

Temperature Ratings

- Storage 0 to 50°C non-condensing.
- Operating 0 to 40°C non-condensing.

Enclosure

The *GENII CS REM* Modules are housed in switchplate that mounts in standard electrical wall plates.

Colour: White

Wall mounted.

Installation

- The Cable run between the *GENII CS REM* and the GENII RMI should not exceed 500 mtrs. The Comms wiring requires cable *especially* suited for RS485. Other shielded cable is not suitable and will cause spasmodic Comms failures.
- Strictly follow the guidelines when installing the Comms wiring as outlined in the Genesis II Installation Manual.
- Mount the *GENII CS REM* in a dry and clean location free of excess vibration.

The REM address must be set by programming Parameter 0. Please refer to the *Program Functions* section of this data sheet for more specific information regarding this.

Wiring

- The cable used for RS485 Comms must be shielded single twisted pair, 120 ohms character impedance, 36 to 45pF per metre capacitance between conductors.
- The Comms cable must be organised as a bus topology. That is, starting at one end, devices are connected to it until the other end of the cable is reached. No "stubs" are allowed. To connect a device to the cable, as cut is made in the cable at the point where the device is to be situated along it. Then, the two new ends of the cable are wired into the device. The shields from the two new ends are then terminated into the terminals marked SHLD1 and SHLD2. Refer to the Genesis Network Installation Instructions for more information.

FCC Class A Notice

This device complies with Part 15 of the FCC Rules.



Operation is subject to the following two conditions:

- This device may not cause harmful interference.
- This device must accept any interference received, including interference that may cause undesired operation.



Note – This equipment has been tested and found to comply with the limits for a Class A digital device, pursuant to Part 15 of the FCC Rules. These limits are designed to provide reasonable protection against harmful interference when the equipment is operated in a commercial environment. This equipment generates, uses and can radiate radio frequency energy and, if not installed and used in accordance with the instruction manual, may cause harmful interference to radio communications. Operation of this equipment in a residential area is likely to cause harmful interference in which case the user will be required to correct the interference at his own expense. Modifications to this device, may void the authority granted to the user by the FCC to operate this equipment.

PROGRAM FUNCTIONS ON THE GENII CS REM

TO ENTER PROGRAMMING MODE:

To enter Programming Mode depress and hold the  and  buttons for 5 seconds. The display will become blank indicating that you are in the Programming Mode. Release both keys and the display will show parameter 0.

Whilst in the programming mode the following buttons are active:

-  Change to the next parameter.
-  Increase the current parameters value.
-  Decrease the current parameters value.

PARAMETER 0: REM ADDRESS

The display will show current REM Address of the device.

The range of address is 0 to 15.

The default address is 0.

PARAMETER 1: MAXIMUM INPUT VALUE:

The display will show the Maximum Input Value to which the module's input can be set.

The range of Maximum Input Value is 0.0 to 99.9.

The factory default setting is 30.0



PARAMETER 2: MINIMUM INPUT VALUE:

The display will show the Minimum Input Value to which the module's input can be set.

The range of Minimum Input Value is 0.0 to 99.9.



The factory default setting is 15.

TO EXIT PROGRAMMING MODE:

To exit the Programming Mode depress the  and  buttons and the new setting will be saved.

START UP DEFAULT SETTINGS:

The *GENII CS REM* Module can be set to start in any mode of operation.

To set the start up default adjust the *GENII CS REM* Module to the desired settings and then press and hold the  and  buttons for 5 seconds.

The display will become blank indicating that the new settings are saved.



OPERATING FUNCTIONS ON THE GENII CS REM

NUMERICAL OUTPUT:

The *GENII CS REM* Module will display a 3 digit, single decimal place analogue output value during normal operation.

NUMERICAL INPUT:

The *GENII CS REM* Module will provide a 3 digit, single decimal place analogue input value to the GENESIS Controller during normal operation.

This value can be modified by pressing the  button to increment by 0.1 or the  button to decrement by 0.1.

DIGITAL INPUT TOGGLE VALUE:

The  button on the *GENII CS REM* Module provides a digital input value to the GENESIS Controller during normal operation.

This operates as a standard toggle switch, i.e. Press the  button once to change the state of the digital input.



The state of the digital input value can also be changed by the Timer on the *GENII CS REM* Module.

DIGITAL OUTPUT LED:

The *GENII CS REM* displays a digital state via the system LED during normal operation.

TIMER OPERATION:

The Timer on the *GENII CS REM* Module allows for automatic toggling of the digital input value. Pressing the

 button allows the timer to be set at a value from 10 minutes to 24 hours. Successive pressing of the  button will increment the timer value until it reaches 24 hours, in which case it then resets to the value of 10 minutes. The timer LED indicates that the timer is active. When the timer value is reached the *GENII CS REM* Module will automatically toggle the digital input value. This has the same effect as the  button being pressed manually

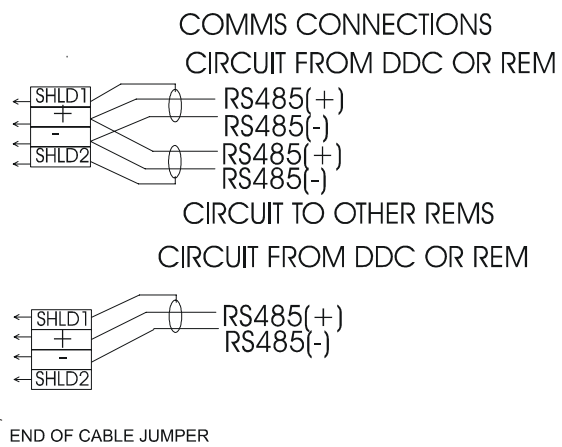
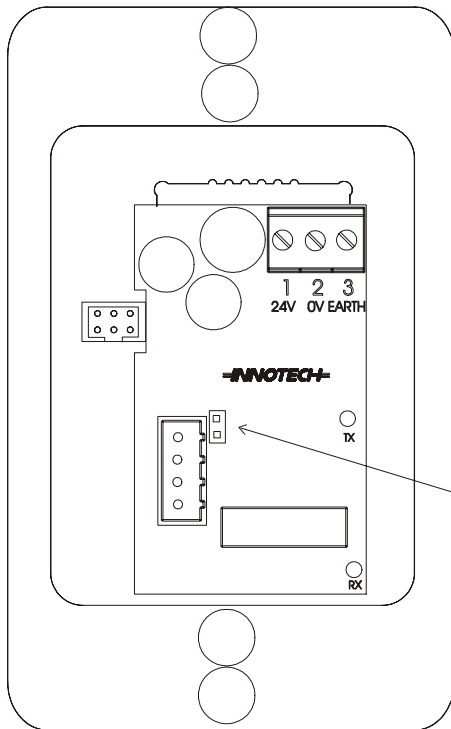

INNOTECH[®]

Innovative technology

Australian Owned, Designed & Manufactured
by Mass Electronics Brisbane

Phone: + 61 7 3841 1388 Fax: + 61 7 3841 1644
Email: sales@innotech.com.au www.innotech.com.au

YOUR DISTRIBUTOR