

SENR1, SENR2, SENR5, SENR6.

Wireless Temperature Sensors

Overview

The Innotech *SENRx* series Wireless Temperature Sensors are remote expansion devices for the GENESIS range of Digital Controllers.

The *SENRx* modules are designed to be remotely located from the GENESIS Digital Controller and provide: a thermistor input for temperature measurement, a digital pushbutton input for after hours status detection, an analogue input for setpoint adjustment and a digital low battery indicator. Table 1 shows the input configuration for each model in the *SENRx* range.

There are no physical connections to a *SENRx* module. A wireless communications protocol is used to transmit the input data to a *GENII WMI* Wireless Module Interface. The *GENII WMI* receives this information and relays it over the RS485 link that communicates with other REM Modules at 38.4kbaud. See the *GENII WMI* datasheet for further information.

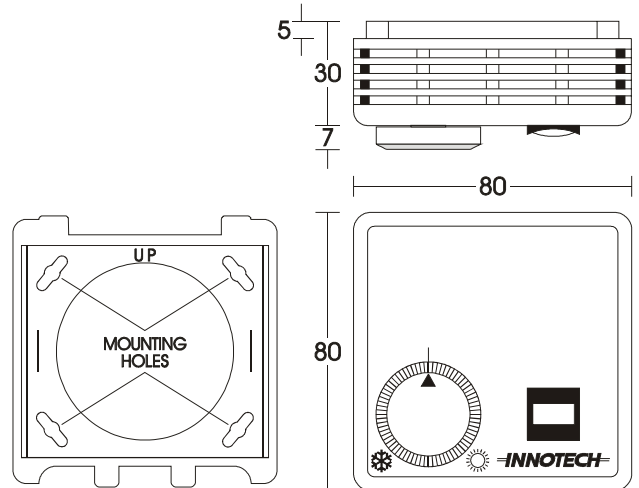

Features

- Wireless remote sensing of input points up to 20m (depending on obstructions) from the GENESIS REM network via a single 10k Ω thermistor temperature sensor, one digital pushbutton input and one analogue input (20k Ω potentiometer).
- 3.6V DC battery operation.
- Minimum 12 months battery life.
- Low Battery indication available as a Digital Input in GEN2Config software.
- RF Comms at 250kbaud.
- Input values transmitted at 20 second intervals.
- Pushbutton status change reported immediately.
- Selectable "Transmit Test Mode" to aid installation.
- Jumper selectable REM Network Address (1-15).
- Jumper selectable RF Frequency (2400-2524MHz).
- Wiring diagrams for modules generated by GEN2Config software.

Applications

- Wireless sensing of temperature, setpoint adjust and after hours request status.
- Any situation where it is impractical to lay cable for zone temperature measurement or where the sensor needs to be relocatable.

Approvals

The Innotech *SENRx* series Wireless Temperature Sensors conform to the requirements of the Australian/New Zealand standard AS/NZS CISPR 22:2002 Class A for the purposes of C-Tick certification.

	<i>Temperature Sensor</i>	<i>Low Battery Indicator</i>	<i>Set Point Adjustment</i>	<i>After Hours Button</i>
SENR1	👍	👍		
SENR2	👍	👍	👍	
SENR5	👍	👍		👍
SENR6	👍	👍	👍	👍

Table 1: *SENRx* Series Input Configurations

Application Notes

A GENESIS Controller must have version 4 (or higher) firmware installed to support REM Modules. Version 5.10 (or higher) software must be used to configure a GENESIS Digital Controller that has *SENRx* modules connected.

One GENESIS Digital Controller can have up to 15 GENII REM Modules attached to it. However, each REM Module has a “Resource Count” value that represents its requirement for GENESIS Digital Controller resources. A GENESIS Digital Controller supports a total resource count of 36. The following shows the Resource Count for each of the currently available REM Modules:

Remote Module	Description	Resource Count
<i>SENR1</i>	<i>Wireless Temperature Sensor</i>	2
<i>SENR2</i>	<i>Wireless Temperature Sensor</i>	3
<i>SENR5</i>	<i>Wireless Temperature Sensor</i>	2
<i>SENR6</i>	<i>Wireless Temperature Sensor</i>	3
GENII WMI	Wireless Module Interface	0
GENII MP050 REM	Multipoint Module	3
GENII MP140 REM	Multipoint Module	4
GENII MP230 REM	Multipoint Module	5
GENII MP320 REM	Multipoint Module	6
GENII AI REM	Analogue Input Module	6
GENII AO REM	Analogue Output Module	5
GENII DO REM	Digital Output Module	1
GENII DI REM	Dry Contact Digital Input Module	1
GENII IDI REM	Opto-Isolated Digital Input Module	1
GENII PI REM	Pulse Input Module	5
GENII CS REM	Control Station Module	4
GENII CSAH REM	Control Station After-Hours Module	4
GENII CSFAH REM	Control Station with 3 Speed Fan	4
GENII MZS REM	Multi Zone Station Module	5
GENII MZSAH REM	Multi Zone After-Hours Station Module	5

Specifications

Power Supply

- 1 x Voltage: 3.6 Volt ½AA Lithium Battery.
- Battery Life: 12 Months min.

Inputs

- 10kΩ thermistor temperature sensor.
- 1 x momentary action pushbutton digital input (*SENR5* & *SENR6* only).
- 1 x 20kΩ potentiometer analogue input (*SENR2* & *SENR6* only).

RF Communications

SENRx Modules operate within the 2.4-2.5GHz worldwide unlicensed Industrial-Scientific-Medical (ISM) frequency band.

Enclosure

The *SENRx* Modules are housed in a square case manufactured from an ignition resistant grade of ABS, which meets the requirements of AS2420.

Colour: Off white.

Mounting: Wall mounted.

Temperature Ratings

- Storage 0 to 50°C non-condensing.
- Operating 0 to 40°C non-condensing.

Installation

- *SENRx* modules should be mounted within a 20m radius (depending on obstructions) of the *GENII WMI* Wireless Module Interface in a dry and clean location free of excess vibration.
- To remove the battery from a *SENRx* module, simply insert a flat screwdriver underneath the battery between the two clips and lever the battery out. When re-inserting the battery, press and hold the “RESET” button. Release the “RESET” button after the battery is located back in the clips. Note the correct polarity as marked on the PCB.
- There are two sets of four jumpers located on the back of the *SENRx* module*. The set of jumpers closest to the battery are labeled A0, A1, A2 & A3. These set the network address of the *SENRx* module in the same manner as *GENII REM* products. Directions for setting the address are shown in the wiring diagram generated by the GEN2Config software. The jumpers located on the far right of the *SENRx* module are labeled F0, F1, F2 & F3. These select the frequency channel to use within the 2.4-2.5GHz range. Typically, these jumpers need only be changed if multiple Wireless Module Interfaces are used or in areas with poor reception or strong interference. The frequency jumpers on the *SENRx* module must exactly match the frequency jumpers on the *GENII WMI* module to be communicated with.
- Also located on the back of the *SENRx* module are the “TEST” and “RESET” buttons. These can be used during installation to help select suitable locations for the modules. Holding the “TEST” button and pushing “RESET” will cause the device to enter “Transmit Test Mode”. In this mode, the *SENRx* module will transmit data every second for the next 3 minutes (and afterwards return to normal operation). The *GENII WMI* will indicate if the *SENRx* module is within range by flashing its “RF-RX” LED at 1second intervals when data is received. Intermittent or no RF-RX LED activity at the *GENII WMI* shows poor reception.
- Further information on selecting suitable mounting locations is available in the *User Instructions for SENRx & GENII WMI*.

*Note:

If any jumpers on a module need to be changed, the unit must be powered down before the jumpers are altered. This can be achieved by removing the battery as described above. Anti-static precautions should be taken when changing jumpers or removing the battery.

SIMPLE SENSOR NETWORKING

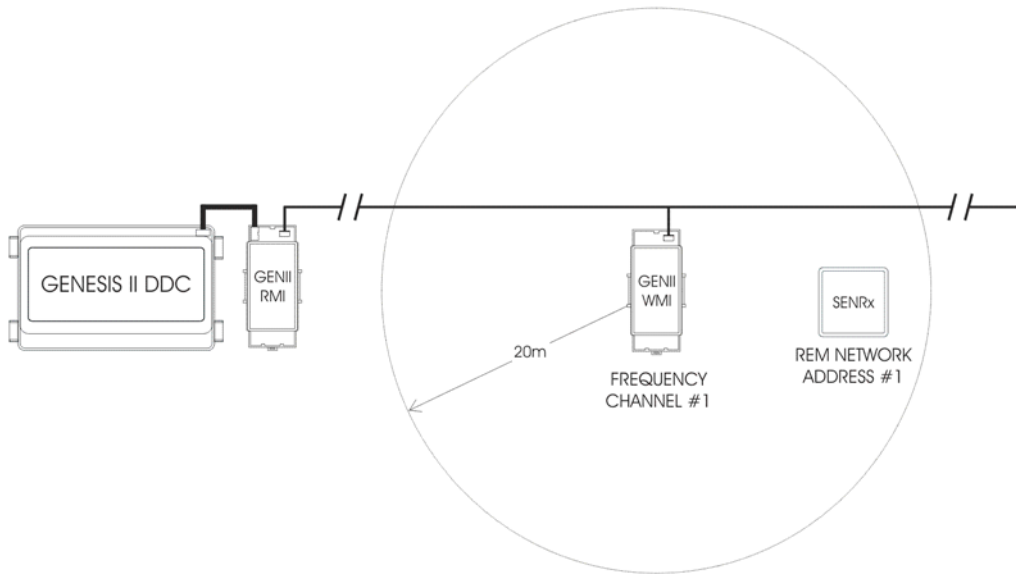

NETWORK WITH MULTIPLE WIRELESS SENSORS & INTERFACE MODULES

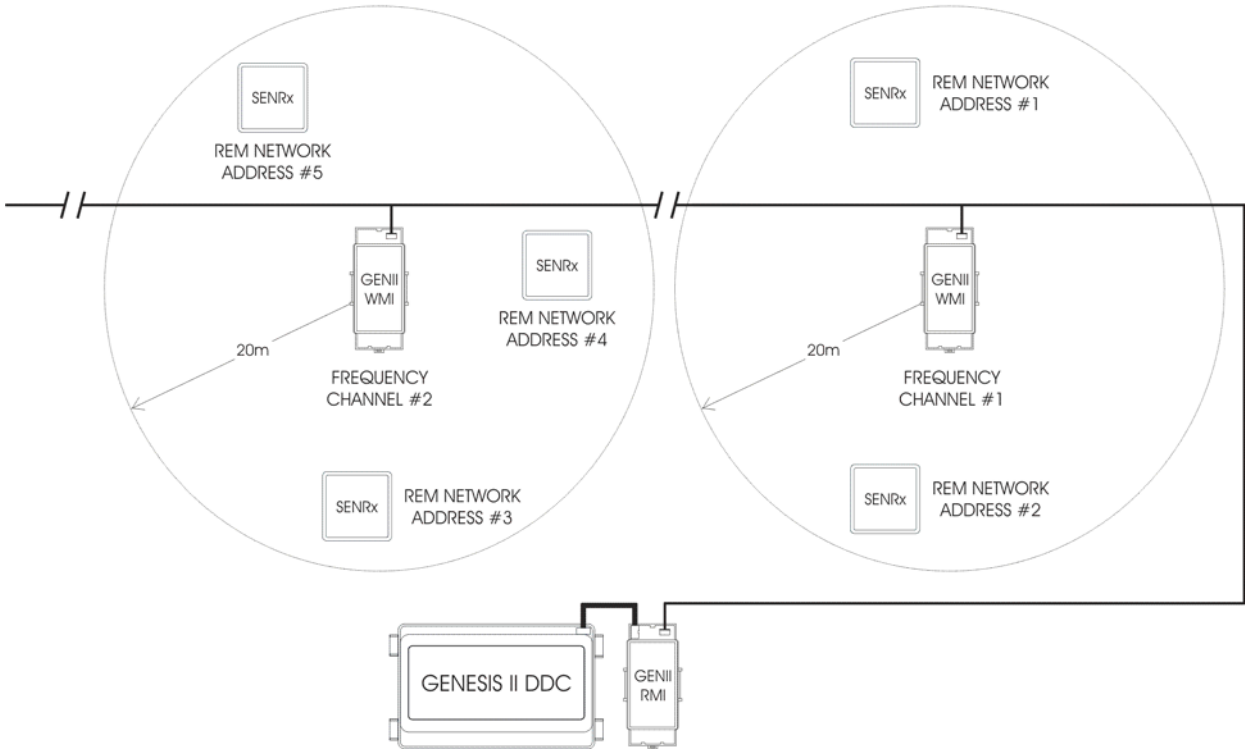

JUMPER LOCATIONS

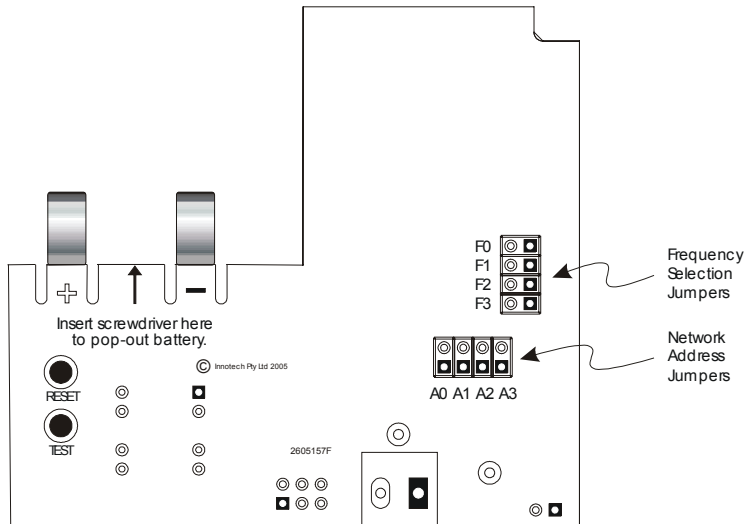

INNOTECH[®]

Innovative technology

Australian Owned, Designed & Manufactured
by Mass Electronics Brisbane

Phone: + 61 7 3841 1388 Fax: + 61 7 3841 1644
Email: sales@innotech.com.au www.innotech.com.au

YOUR DISTRIBUTOR